



2023 | TRANCIATURA | SHEARING | SCHNEIDELEMENTE UND ZUBEHÖR

TRANCIATURA | SHEARING | SCHNEIDELEMENTE UND ZUBEHÖR



SYNDAL srl
Via Cesare Battisti 2
20090 Trezzano sul Naviglio (MI)
T +39 02 4842051

Via I Maggio 10
40011 Anzola dell'Emilia (BO)
T +39 051 0561910

info@syndal.it
syndal.it



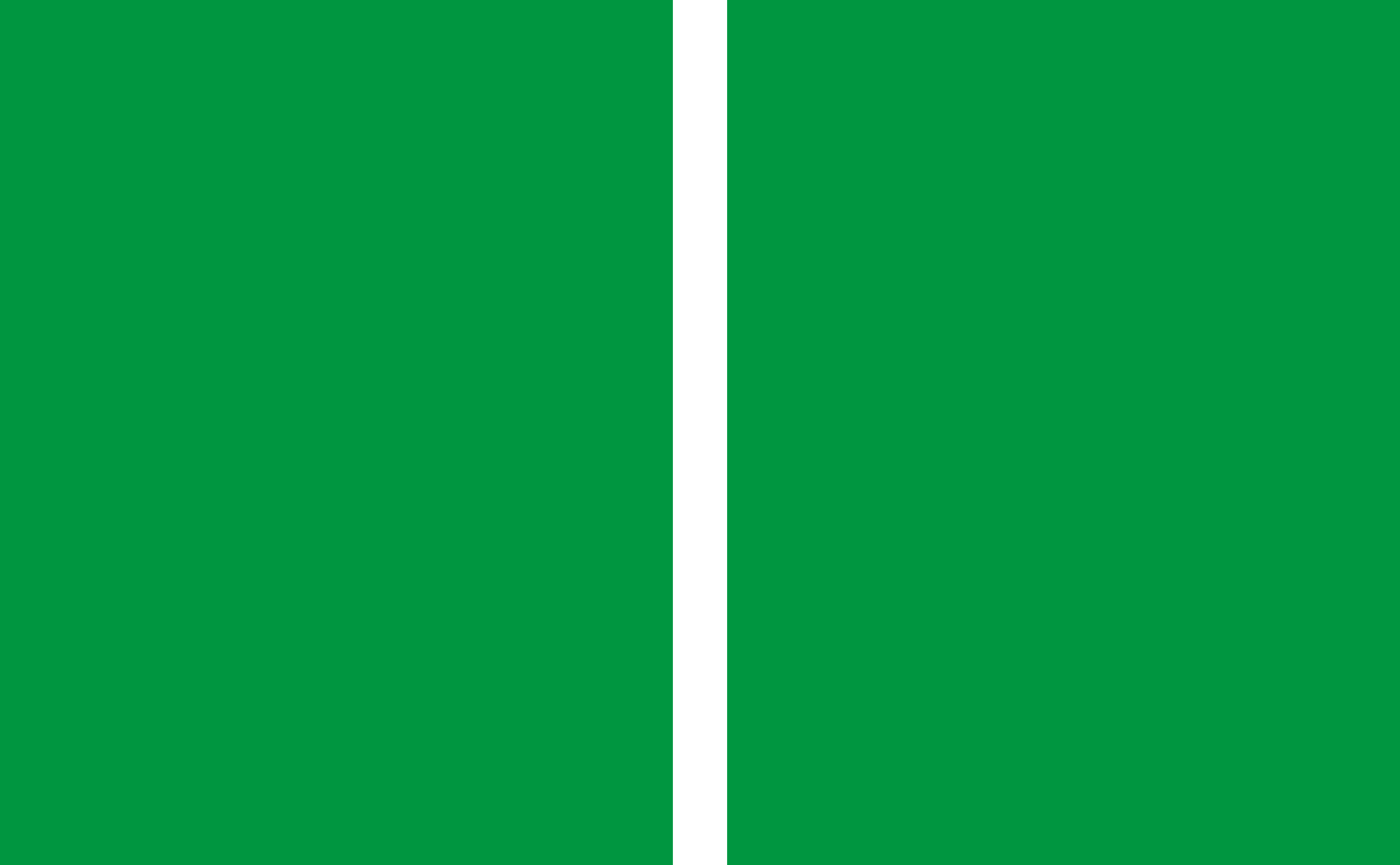



TRANCIATURA

SHEARING / SCHNEIDEN

I sistemi di **Tranciatura** scelti da Syndal assicurano all'utente qualità e performance nella tranciatura della lamiera, continui test aziendali confermano i nostri standard. La scelta dei materiali D2 (WS), A2 (HWS), M2 (HSS) e sinterizzati, abbinati alle moderne tecniche di tempra, rinvenimento e rivestimento, consolidano e certificano la **qualità** del prodotto distribuito.

Syndal completa la gamma di punzoni e matrici promuovendo la costruzione di normative Din, ISO e qualsiasi elemento speciale con indicazioni a disegno.

The **shearing** systems selected by Syndal guarantee its customers quality and performance in the metal sheet shearing, constant tests confirm our standards. The selection of D2 (WS), A2 (HWS), M2 (HSS) and sintered materials, combined with modern quenching, tempering and coating techniques, strengthens and certifies the **quality** its products.

Syndal completes punch and matrix range offering construction in accordance with Din and ISO certifications, but it is also able to satisfy any special request based on drawing supplied by customers.

Das von Syndal gewählte **Stanzsystem** garantiert unseren Kunden höchste Qualität und Leistung. Ständige Überprüfungen der Fertigung bestätigen die Qualität unserer Produkte. Die Verwendung der Werkstoffe D2 (WS), A2 (HWS), M2 (HSS) kombiniert mit **hochwertiger** Vergütung und Beschichtung, stärkt die Produktivität unserer Produkte.

Syndal komplettiert den DIN und ISO Bereich für Lochstempel und Schneidbuchsen mit den vom Kunden gewünschten Werkstoffen und der Fertigung nach Datensätzen oder Zeichnungen.



INDICE

CONTENTS

T1

102	PUNZONE DIN 9861 ISO 6752 PUNCH DIN 9861 ISO 6752 SCHNEIDSTEMPEL DIN 9861 ISO 6752	09	
1R/1J	PUNZONE RIBASSATO DIN 9861 ISO 6752 PUNCH DIN 9861 ISO 6752, STEPPED SCHNEIDSTEMPEL DIN 9861 ISO 6752, ABGESETZT	10	
2RB/2JB	PUNZONE TESTA RINFORZATA REINFORCED HEAD PUNCH SCHNEIDSTEMPEL MIT VERSTÄRKTEM KOPF	12	
2R/2J	PUNZONE TESTA RINFORZATA RIBASSATO REINFORCED HEAD PUNCH, STEPPED SCHNEIDSTEMPEL MIT VERSTÄRKTEM KOPF ABGESETZT	14	
3RB/3JB	PUNZONE ISO 8020 A/E PUNCH ISO 8020 SCHNEIDSTEMPEL ISO 8020	16	
3R/3J	PUNZONE ISO 8020 B/F RIBASSATO PUNCH ISO 8020, STEPPED SCHNEIDSTEMPEL ISO 8020, ABGESETZT	18	
4RB/4JB	PUNZONE A COLLO DI TROMBONE PUNCH WITH TAPERED SCHNEIDSTEMPEL MIT POSAUNENHALS	20	
4R/4J	PUNZONE A COLLO DI TROMBONE RIBASSATO PUNCH WITH TAPERED, STEPPED SCHNEIDSTEMPEL MIT POSAUNENHALS, ABGESETZT	22	
5RB/5JB	PUNZONE TP PUNCH TP SCHNEIDSTEMPEL TP	24	
5R/5J	PUNZONE TP RIBASSATO PUNCH TP, STEPPED SCHNEIDSTEMPEL TP, ABGESETZT	26	

T9

3RT/3RTS	PORTAPUNZONE RETAINER AUFNAHMEPLATTE	28	
3OT/3OTS	PORTAPUNZONE RETAINER AUFNAHMEPLATTE	29	
3UR/3UO	PIASTRINE DI REAZIONE SHIM PLATE DRUCKPLATTE	30	

T7	1101	STARK STRIP / STARK STRIP STARK STRIP	33	
	8058	TESTINA SBOZZATA / BLANK HEAD VORGESCHLIFFENER KOPF	36	
T2	103/113	MATRICE DIN 9845 CON / SENZA TESTA MATRIX DIE DIN 9845 WITH / WITHOUT SHOULDER SCHNEIDBUCHSE DIN 9845 MIT / OHNE BUND	39	
	3D	MATRICE ISO 8977 SENZA TESTA MATRIX DIE ISO 8977 WITHOUT SHOULDER SCHNEIDBUCHSE ISO 8977 OHNE BUND	40	
	3H	MATRICE ISO 8977 CON TESTA MATRIX DIE ISO 8977 WITH SHOULDER SCHNEIDBUCHSE ISO 8977 MIT BUND	42	
T4	119P/119Z	PUNZONE MARCHIO STAMP BUCHSTABENSTEMPEL	44	
	219/229	PORTATIMBRI / REAZIONE RETAINER / BACKING PLATE HALTEPLATTE / DRUCKPLATTE	45	
T5	102	ESPULSORE DIN 9861 EJECTOR PIN DIN 9861 SCHNEIDSTEMPEL NACH DIN 9861	47	
	202.0A	ESPULSORE TESTA CILINDRICA ISO 1530-1 NITRURATO EJECTOR ISO 1530-1 NITRURED AUSWERFERSTIFT ISO 1530-1 NITRIERT	48	
	202.AH	ESPULSORE TESTA CILINDRICA ISO 1530-1 TEMPERATO EJECTOR ISO 1530-1 THROUGH - HARDNED AUSWERFERSTIFT ISO 1530-1 GEHÄRTET	49	
	206.0A	ESPULSORE TESTA CILINDRICA ISO 1530-1 FIAT EJECTOR ISO 1530-1 FIAT AUSWERFERSTIFT ISO 1530-1 FIAT	50	



ALTERAZIONI

ALTERATION / SPEZIFIKATION

DD Diametro del corpo inferiore allo standard
DD Reduced Shank Diameter
DD Reduzierter Schaftdurchmesser

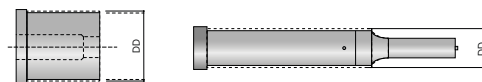

1R 1J
 2R 2J
 3R 3J
 3D 3H
 4R 4J
 5R 5J

DL Lunghezza totale diversa dallo standard
LL Tolleranza sulla lunghezza totale di ± 0.02
DL Overall Length Shortened
LL Precision Overall Length $\pm 0,02$ mm
DL Kürzen der Gesamtlänge an der Schneide ggf. DB angeben
LL Präzisionsgesamtlänge $\pm 0,02$ mm

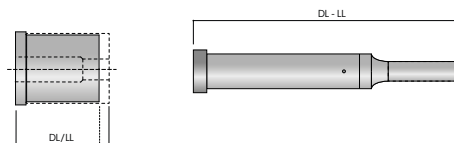

1R 1J
 2R 2J
 3R 3J
 3D 3H
 4R 4J
 5R 5J

DP Dimensione quota P inferiore allo standard
DW Dimensione quota W inferiore allo standard
DP P Dimension Smaller Than Standard
DW W Dimension Smaller Than Standard
DP Maß P kleiner als Standard
DW Maß W größer oder kleiner als Standard

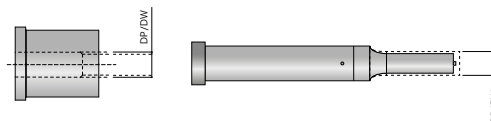

1R 1J
 2R 2J
 3R 3J
 3D 3H
 4R 4J
 5R 5J

DB Lunghezza quota B diversa dal range indicato
DB Point Length Longer Than Standard B
DB Schneidlänge, größer als Standard B und Länge angeben

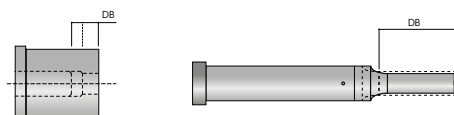

1R 1J
 2R 2J
 3R 3J
 3D 3H
 4R 4J
 5R 5J

DH Diametro della testa inferiore allo standard
DH Reduced Head Diameter
DH Reduzierter Kopfdurchmesser

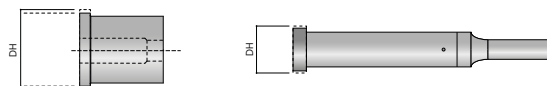

3R
 3J
 3H
 5R
 5J

DT Dimensione dello spessore della testa diversa dallo standard
TT Tolleranza dello spessore della testa ± 0.01
DT Thinner Head Than Standard
TT Precision Head Thickness ± 0.01
DT Reduzierte Kopfstärke
TT Präzisionskopfstärke $\pm 0,01$ mm

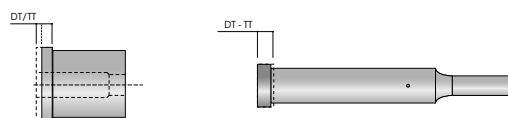

3R
 3J
 3H
 5R
 5J

LJ Distanza del foro di affilatura specifico
LJ Distance of the specific sharpening hole
LJ Abstand des spezifischen Schärflöchs

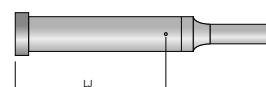

1J
 2J
 3J
 4J
 5J

DJ Esecuzione senza foro di affilatura
DJ No Side Hole
DJ kein Seitenloch

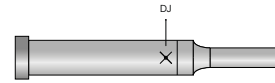

1J
 2J
 3J
 4J
 5J

DR Diametro dello scarico della matrice diverso dallo standard
DR Diameter of the matrix drain different than standard
DR Durchmesser des Lochs der Freimachung abweichend vom Standard

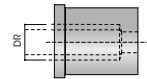

3D
 3H

DBL Parte tranciante per tutta la lunghezza della matrice
DBL Straight Through Land
DBL Formdurchgehend

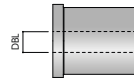

3D
 3H

DC Trasformazione dello scarico della matrice da cilindrica a conica
DC Transformation of the matrix drain from conical cone
DC Konische Freinnachung

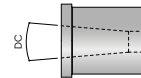

3D
 3H

DSC Controllo anti-slug su matrici
DSC Slug Control Eliminates slug pulling
DSC Budzenstopp

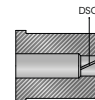

3D
 3H

DTN Rivestimento TiN
DTN TiN Coating
DTN TiN - Beschichtung

DTCN Rivestimento TiCN
DTCN TiCN Coating
DTCN TiCN - Beschichtung



T1.1 PUNZONE DIN 9861 ISO 6752

T1.1 PUNCH DIN 9861 ISO 6752

T1.1 SCHNEIDSTEMPEL DIN 9861 ISO 6752

T1.102

Punzone DIN 9861 ISO 6752

Punch DIN 9861 ISO 6752

Schneidstempel DIN 9861 ISO 6752

Esecuzione: Rettificato e lappato

Execution: Shaft is grinded and lapped

Ausführung: Schaft, geschliffen und geläppt

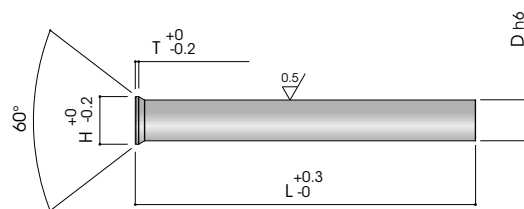

D	H	T	71	80	100
1÷1,1	1,8	0,5	•	•	•
1,2÷1,3	2	0,5	•	•	•
1,4÷1,9	2,2	0,5	•	•	•
2	3	0,5	•	•	•
2,1÷2,5	3,2	0,5	•	•	•
2,6÷2,9	4	0,5	•	•	•
3÷3,4	4,5	0,5	•	•	•
3,5÷3,9	5	0,5	•	•	•
4÷4,4	5,5	0,5	•	•	•
4,5÷4,9	6	0,5	•	•	•
5÷5,4	6,5	0,5	•	•	•
5,5÷5,9	7	0,5	•	•	•
6÷6,4	8	0,5	•	•	•
6,5÷7,4	9	1	•	•	•

D	H	T	71	80	100
7,5÷8,4	10	1	•	•	•
8,5÷9,4	11	1	•	•	•
9,5÷10,4	12	1	•	•	•
10,5÷11,4	13	1	•	•	•
11,5÷12,4	14	1	•	•	•
12,5÷13,4	15	1	•	•	•
13,5÷14,4	16	1,5	•	•	•
14,5÷15	17	1,5	•	•	•
15,10÷16	18	1,5	•	•	•
16,10÷17	19	1,5	•	•	•
17,10÷18	20	1,5	•	•	•
18,10÷19	21	1,5	•	•	•
19,10÷20	22	1,5	•	•	•

MATERIALI

Material / Werkstoff

CODE	DESCRIPTION	BODY HARDNESS	HEAD HARDNESS
D2	WS / 1.2210	60-62 HRC	40-45 HRC
A2	HWS / 1.2436	60-63 HRC	40-45 HRC
M2	HSS / 1.3343	62-64 HRC	50-53 HRC
PS	ASP23	63-65 HRC	50-53 HRC

ALTRO MATERIALE A RICHIESTA

OTHER MATERIAL ON REQUEST / ANDERER WERKSTOFF AUF ANFRAGE

COME ORDINARE

How to order / Bestellbeispiel

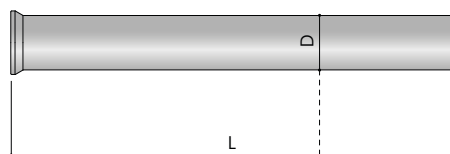

Qty 10 Type T1.102 Material M2 D 16 L 100

Su richiesta da ø 3 fornibili con espulsore

On request from ø 3 available with ejector / Auf Wunsch ø 3 mit Auswerfer Lieferbar

T1.1 PUNZONE RIBASSATO DIN 9861 ISO 6752

T1.1 PUNCH DIN 9861 ISO 6752, STEPPED

T1.1 SCHNEIDSTEMPEL DIN 9861 ISO 6752, ABGESETZT

T1.1R

Punzone DIN 9861 ISO 6752

Punch DIN 9861 ISO 6752

Schneidstempel DIN 9861 ISO 6752

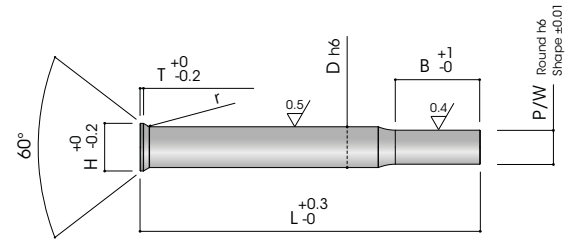

T1.1J

Punzone DIN 9861 ISO 6752 con espulsore

Punch DIN 9861 ISO 6752 with ejector

Schneidstempel DIN 9861 ISO 6752 mit Abdrückstift

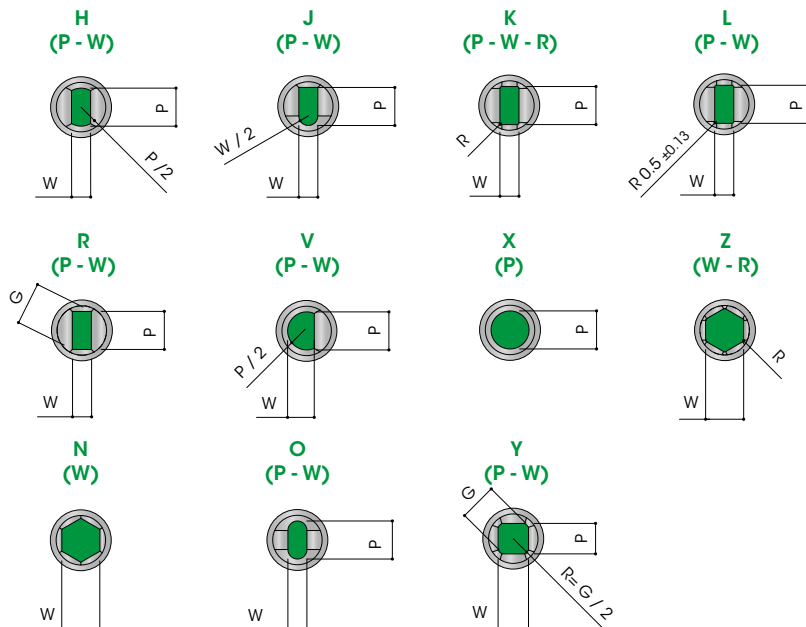
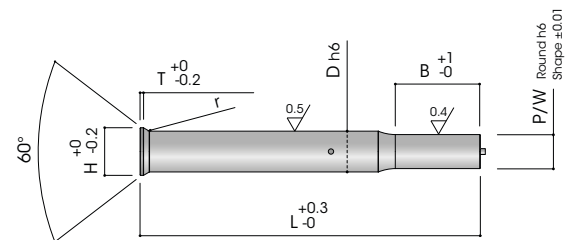

MATERIALI

Material / Werkstoff

CODE	DESCRIPTION	BODY HARDNESS	HEAD HARDNESS
A2	HWS / 1.2436	60-63 HRC	40-45 HRC
M2	HSS / 1.3343	62-64 HRC	50-53 HRC
PS	ASP23	63-65 HRC	50-53 HRC

ALTRO MATERIALE A RICHIESTA

OTHER MATERIAL ON REQUEST / ANDERER WERKSTOFF AUF ANFRAGE

COME ORDINARE

How to order / Bestellbeispiel

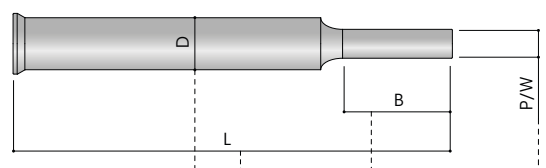

Qty	Type	Material	D	L	Dim. Shape	B	Key Flat	Alteration
10	T1.1RX	M2	16	100	P12.5	B22	K2	DL98

T1.1 PUNZONE RIBASSATO DIN 9861 ISO 6752

T1.1 PUNCH DIN 9861 ISO 6752, STEPPED

T1.1 SCHNEIDSTEMPEL DIN 9861 ISO 6752, ABGESETZT

CODE	D	H	T	R	RANGE P	RANGE B	MIN W	MAX P/G	40	50	56	60	63	70	71	80	90	100	120
T1.1R	3	4.5	0.5	0.6	1.00 ÷ 2.99	8 ÷ 19	1.00	2.95	*	*	*	*	*	*	*	*	*	*	*
	4	5.5	0.5	0.6	1.00 ÷ 3.99	8 ÷ 19	1.60	3.95	*	*	*	*	*	*	*	*	*	*	*
	5	6.5	0.5	0.6	1.60 ÷ 4.99	8 ÷ 19	1.60	4.95	*	*	*	*	*	*	*	*	*	*	*
	6	8	0.5	0.6	1.60 ÷ 5.99	13 ÷ 25	1.60	5.95	*	*	*	*	*	*	*	*	*	*	*
	7	9	1	1	2.50 ÷ 6.99	13 ÷ 25	2.50	6.95	*	*	*	*	*	*	*	*	*	*	*
	8	10	1	1	2.50 ÷ 7.99	13 ÷ 25	2.50	7.95	*	*	*	*	*	*	*	*	*	*	*
	9	11	1	1	3.20 ÷ 8.99	13 ÷ 25	3.20	8.95	*	*	*	*	*	*	*	*	*	*	*
	10	12	1	1	3.20 ÷ 9.99	13 ÷ 25	3.20	9.95	*	*	*	*	*	*	*	*	*	*	*
	11	13	1	1	4.00 ÷ 10.99	13 ÷ 25	4.00	10.95	*	*	*	*	*	*	*	*	*	*	*
	12	14	1	1	4.00 ÷ 11.99	13 ÷ 25	4.00	11.95	*	*	*	*	*	*	*	*	*	*	*
T1.1R / T1.1J	13	15	1	1	4.50 ÷ 12.99	13 ÷ 25	4.50	12.95	*	*	*	*	*	*	*	*	*	*	*
	14	16	1.5	1.4	4.50 ÷ 13.99	13 ÷ 25	4.50	13.95	*	*	*	*	*	*	*	*	*	*	*
	15	17	1.5	1.4	8.00 ÷ 14.99	13 ÷ 25	6.00	14.95	*	*	*	*	*	*	*	*	*	*	*
	16	18	1.5	1.4	8.00 ÷ 15.99	13 ÷ 25	6.00	15.95	*	*	*	*	*	*	*	*	*	*	*
	17	19	1.5	1.4	9.00 ÷ 16.99	19 ÷ 30	7.00	16.95	*	*	*	*	*	*	*	*	*	*	*
	18	20	1.5	1.4	9.00 ÷ 17.99	19 ÷ 30	7.00	17.95	*	*	*	*	*	*	*	*	*	*	*
	19	21	1.5	1.4	10.00 ÷ 18.99	19 ÷ 30	8.00	18.95	*	*	*	*	*	*	*	*	*	*	*
	20	22	1.5	1.4	10.00 ÷ 19.99	19 ÷ 30	8.00	19.95	*	*	*	*	*	*	*	*	*	*	*
	25	27	1.5	1.4	12.00 ÷ 24.99	19 ÷ 30	9.00	24.95	*	*	*	*	*	*	*	*	*	*	*
	32	34	1.5	1.4	16.00 ÷ 31.99	19 ÷ 30	10.00	32.95	*	*	*	*	*	*	*	*	*	*	*

PIANI DI ORIENTAMENTO

Key flat / Verdrehsicherungen

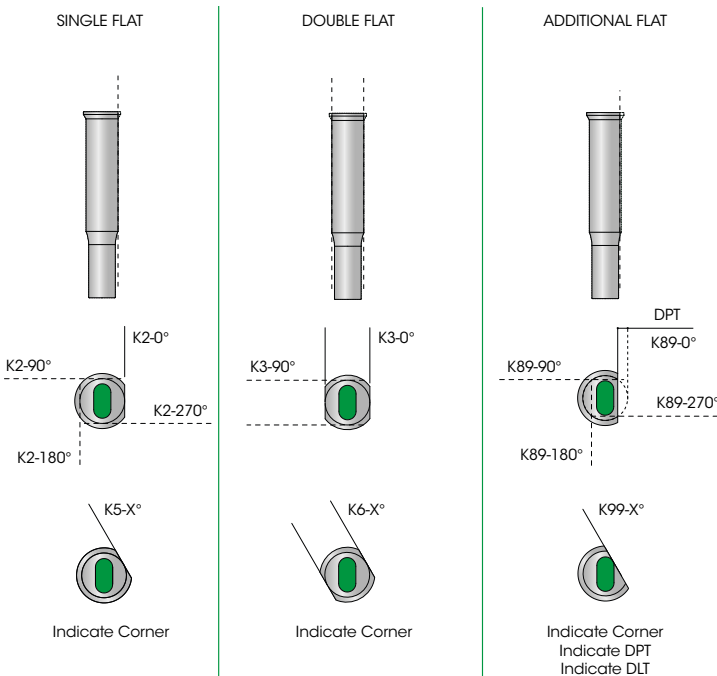

ALTERAZIONI

Alteration / Spezifikation

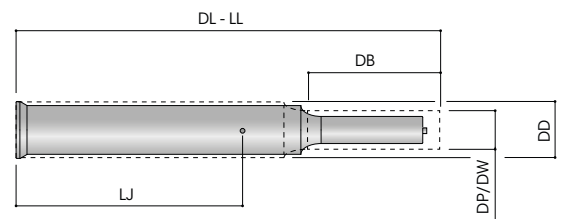

SPECIFICHE ALTERAZIONI A PAGINA 6
ALTERATION 6 PAGE / SPEZIFIKATION AUF SEITE 6

T1.2 PUNZONE TESTA RINFORZATA

T1.2 REINFORCED HEAD PUNCH

T1.2 SCHNEIDSTEMPEL MIT VERSTÄRKTEM KOPF

T1.2RB

Punzone testa rinforzata
Reinforced head punch
Schneidstempel mit Verstärktem Kopf

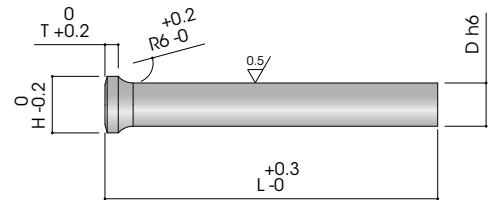

T1.2JB

Punzone testa rinforzata con espulsore
Reinforced head punch with ejector
Schneidstempel mit Verstärktem Kopf mit Abdrückstift

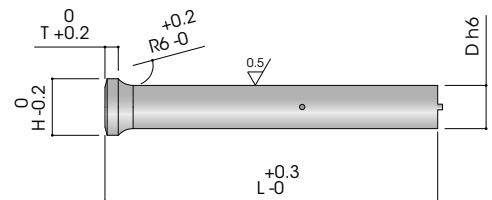

Esecuzione: Rettificato e lappato
Execution: Shaft is grinded and lapped
Ausführung: Schaft, geschliffen und geläpft

MATERIALI

Material / Werkstoff

CODE	DESCRIPTION	BODY HARDNESS	HEAD HARDNESS
A2	HWS / 1.2436	60-63 HRC	40-45 HRC
M2	HSS / 1.3343	62-64 HRC	50-53 HRC
PS	ASP23	63-65 HRC	50-53 HRC

ALTRO MATERIALE A RICHIESTA
OTHER MATERIAL ON REQUEST / ANDERER WERKSTOFF AUF ANFRAGE

COME ORDINARE

How to order / Bestellbeispiel

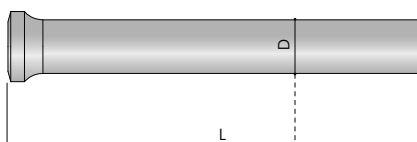

Q.ty	Type	Material	D	L
10	T1.2RB	M2	16	100

ALTERAZIONI

Alteration / Spezifikation

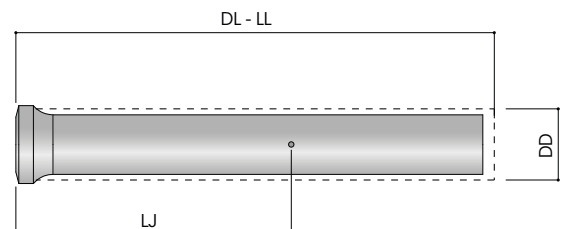

SPECIFICHE ALTERAZIONI A PAGINA 6
ALTERATION 6 PAGE / SPEZIFIKATION AUF SEITE 6

T1.2 PUNZONE TESTA RINFORZATA

T1.2 REINFORCED HEAD PUNCH

T1.2 SCHNEIDSTEMPEL MIT VERSTÄRKTEM KOPF

D	H	T	71	80	100
2	3.2	2	•	•	•
2.1	3.3	2	•	•	•
2.2	3.4	2	•	•	•
2.3	3.5	2	•	•	•
2.4	3.6	2	•	•	•
2.5	3.8	2	•	•	•
2.6	3.9	2	•	•	•
2.7	4	2	•	•	•
2.8	4.1	2	•	•	•
2.9	4.2	2	•	•	•
3	5	2	•	•	•
3.1	5.1	2	•	•	•
3.2	5.2	2	•	•	•
3.3	5.3	2	•	•	•
3.4	5.4	2	•	•	•
3.5	6	2	•	•	•
3.6	6.1	3	•	•	•
3.7	6.2	3	•	•	•
3.8	6.3	3	•	•	•
3.9	6.4	3	•	•	•
4	6.5	3	•	•	•
4.1	6.6	3	•	•	•
4.2	6.7	3	•	•	•
4.3	6.8	3	•	•	•
4.4	6.9	3	•	•	•
4.5	7	3	•	•	•
4.6	7.1	3	•	•	•
4.7	7.2	3	•	•	•
4.8	7.3	3	•	•	•
4.9	7.4	3	•	•	•
5	8	3	•	•	•
5.1	8.1	3	•	•	•
5.2	8.2	3	•	•	•
5.3	8.3	3	•	•	•
5.4	8.4	3	•	•	•
5.5	8.5	3	•	•	•
5.6	8.6	3	•	•	•
5.7	8.7	3	•	•	•
5.8	8.8	3	•	•	•
5.9	8.9	3	•	•	•
6	9	3	•	•	•
6.1	9.1	3	•	•	•

D	H	T	71	80	100
6.2	9.2	3	•	•	•
6.3	9.3	3	•	•	•
6.4	9.4	3	•	•	•
6.5	10	3	•	•	•
6.6 ÷ 7	10	3	•	•	•
7.1	10.1	3	•	•	•
7.2	10.2	3	•	•	•
7.3	10.3	3	•	•	•
7.4	10.4	3	•	•	•
7.5 ÷ 8	11	3	•	•	•
8.1	11.1	3	•	•	•
8.2	11.2	3	•	•	•
8.3	11.3	3	•	•	•
8.4	11.4	3	•	•	•
8.5 ÷ 9	13	3	•	•	•
9.1	13.1	3	•	•	•
9.2	13.2	3	•	•	•
9.3	13.3	3	•	•	•
9.4	13.4	3	•	•	•
9.5 ÷ 10	14	3	•	•	•
10.1	14.1	4	•	•	•
10.2	14.2	4	•	•	•
10.3	14.3	4	•	•	•
10.4	14.4	4	•	•	•
10.5 ÷ 11	15	4	•	•	•
11.1	15.1	4	•	•	•
11.2	15.2	4	•	•	•
11.3	15.3	4	•	•	•
11.4	15.4	4	•	•	•
11.5 ÷ 12	16	4	•	•	•
12.1	16.1	4	•	•	•
12.2	16.2	4	•	•	•
12.3	16.3	4	•	•	•
12.4	16.4	4	•	•	•
12.5 ÷ 13.4	17	4	•	•	•
13.5 ÷ 14.4	18	4	•	•	•
14.5 ÷ 15.4	19	4	•	•	•
15.5 ÷ 16.9	20	4	•	•	•
17 ÷ 17.9	21	4	•	•	•
18 ÷ 18.9	22	4	•	•	•
19 ÷ 19.9	23	4	•	•	•
20	24	4	•	•	•

T1.2 PUNZONE TESTA RINFORZATA RIBASSATO

T1.2 REINFORCED HEAD PUNCH, STEPPED

T1.2 SCHNEIDSTEMPEL MIT VERSTÄRKTEM KOPF ABGESETZT

T1.2R

Punzone testa rinforzata
Reinforced head punch
Schneidstempel mit Verstärktem Kopf

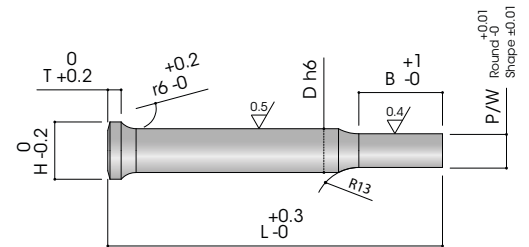

T1.2J

Punzone testa rinforzata con espulsore
Reinforced head punch with ejector
Schneidstempel mit Verstärktem Kopf mit Abdrückstift

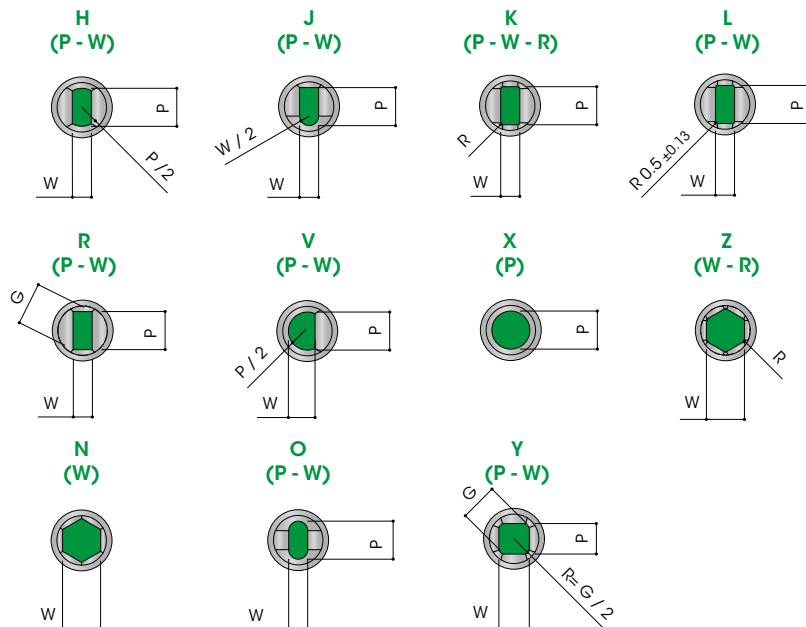
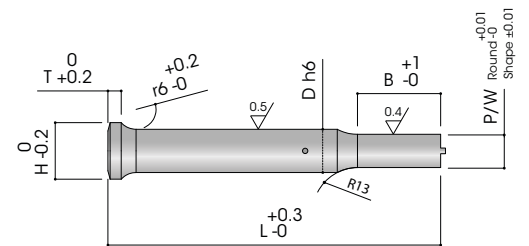

MATERIALI

Material / Werkstoff

CODE	DESCRIPTION	BODY HARDNESS	HEAD HARDNESS
M2	HSS / 1.3343	62-64 HRC	50-53 HRC
PS	ASP23	63-65 HRC	50-53 HRC

ALTRO MATERIALE A RICHIESTA

OTHER MATERIAL ON REQUEST / ANDERER WERKSTOFF AUF ANFRAGE

COME ORDINARE

How to order / Bestellbeispiel

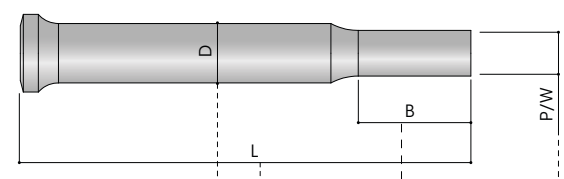

Q.ty	Type	Material	D	L	Dim. Shape	B	Key Flat	Alteration
10	T1.2RX	M2	16	100	P13.2	B22	K2	DL98

T1.2 PUNZONE TESTA RINFORZATA RIBASSATO

T1.2 REINFORCED HEAD PUNCH, STEPPED

T1.2 SCHNEIDSTEMPEL MIT VERSTÄRKTEM KOPF ABGESETZT

CODE	D	H	T	RANGE P	RANGE B	MIN W	MAX P/G	40	50	56	60	63	70	71	80	90	100	120
T1.2R	3	5	2	1.00 ÷ 2.99	8 ÷ 19	1.00	2.95	*	*	*	*	*	*	*	*	*	*	*
	4	6.5	3	1.00 ÷ 3.99	8 ÷ 19	1.60	3.95	*	*	*	*	*	*	*	*	*	*	*
	5	8	3	1.60 ÷ 4.99	8 ÷ 19	1.60	4.95	*	*	*	*	*	*	*	*	*	*	*
	6	9	3	1.60 ÷ 5.99	13 ÷ 25	1.60	5.95	*	*	*	*	*	*	*	*	*	*	*
	7	10	3	2.50 ÷ 6.99	13 ÷ 25	2.50	6.95	*	*	*	*	*	*	*	*	*	*	*
	8	11	3	2.50 ÷ 7.99	13 ÷ 25	2.50	7.95	*	*	*	*	*	*	*	*	*	*	*
	9	13	3	3.20 ÷ 8.99	13 ÷ 25	3.20	8.95	*	*	*	*	*	*	*	*	*	*	*
	10	14	3	3.20 ÷ 9.99	13 ÷ 25	3.20	9.95	*	*	*	*	*	*	*	*	*	*	*
	11	15	4	4.00 ÷ 10.99	13 ÷ 25	4.00	10.95	*	*	*	*	*	*	*	*	*	*	*
	12	16	4	4.00 ÷ 11.99	13 ÷ 25	4.00	11.95	*	*	*	*	*	*	*	*	*	*	*
T1.2R / T1.2J	13	17	4	4.50 ÷ 12.99	13 ÷ 25	4.50	12.95	*	*	*	*	*	*	*	*	*	*	*
	14	18	4	4.50 ÷ 13.99	13 ÷ 25	4.50	13.95	*	*	*	*	*	*	*	*	*	*	*
	15	19	4	8.00 ÷ 14.99	13 ÷ 25	6.00	14.95	*	*	*	*	*	*	*	*	*	*	*
	16	20	4	8.00 ÷ 15.99	13 ÷ 25	6.00	15.95	*	*	*	*	*	*	*	*	*	*	*
	17	21	4	9.00 ÷ 16.99	19 ÷ 30	7.00	16.95	*	*	*	*	*	*	*	*	*	*	*
	18	22	4	9.00 ÷ 17.99	19 ÷ 30	7.00	17.95	*	*	*	*	*	*	*	*	*	*	*
	19	23	4	10.00 ÷ 18.99	19 ÷ 30	8.00	18.95	*	*	*	*	*	*	*	*	*	*	*
	20	24	4	10.00 ÷ 19.99	19 ÷ 30	8.00	19.95	*	*	*	*	*	*	*	*	*	*	*
	25	29	4	12.00 ÷ 24.99	19 ÷ 30	9.00	24.95	*	*	*	*	*	*	*	*	*	*	*
	32	36	4	16.00 ÷ 31.99	19 ÷ 30	10.00	32.95	*	*	*	*	*	*	*	*	*	*	*

PIANI DI ORIENTAMENTO

Key flat / Verdrehsicherungen

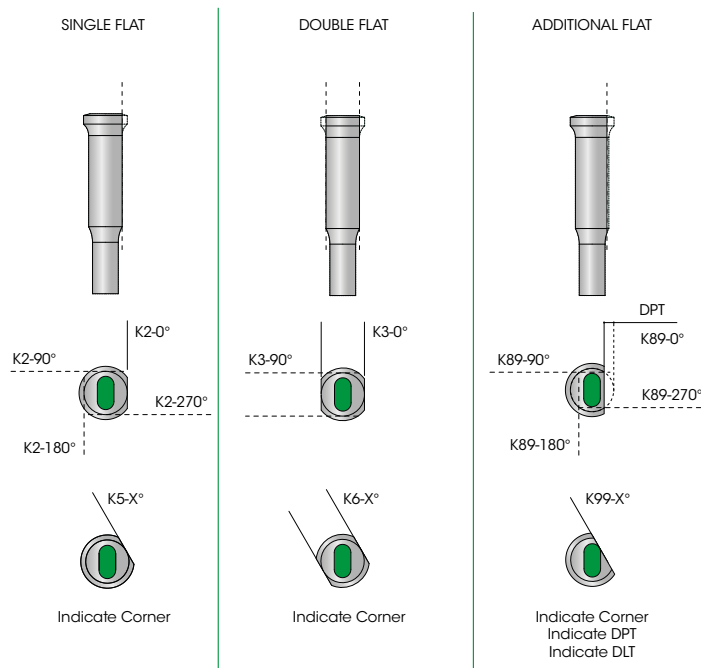

ALTERAZIONI

Alteration / Spezifikation

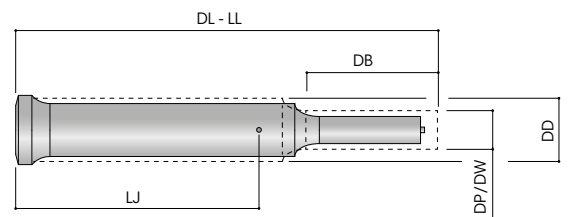

SPECIFICHE ALTERAZIONI A PAGINA 6
ALTERATION 6 PAGE / SPEZIFIKATION AUF SEITE 6

T1.3 PUNZONE ISO 8020 A/E

T1.3 PUNCH ISO 8020

T1.3 SCHNEIDSTEMPEL ISO 8020

T1.3RB/RI

Punzone ISO 8020

Punch ISO 8020

Schneidstempel ISO 8020

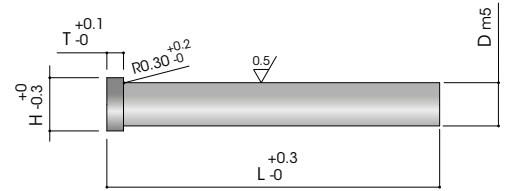

T1.3JB/JI

Punzone ISO 8020 con espulsore

Punch ISO 8020 with ejector

Schneidstempel ISO 8020 mit Abdrückstift

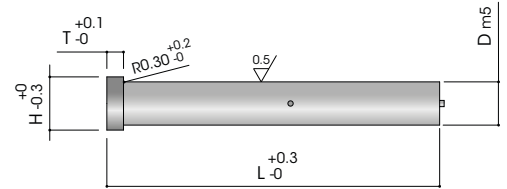

Esecuzione: Rettificato e lappato

Execution: Shaft is grinded and lapped

Ausführung: Schaft, geschliffen und geläppt

MATERIALI

Material / Werkstoff

CODE	DESCRIPTION	BODY HARDNESS	HEAD HARDNESS
A2	HWS / 1.2436	60-63 HRC	40-45 HRC
M2	HSS / 1.3343	62-64 HRC	50-53 HRC
PS	ASP23	63-65 HRC	50-53 HRC

ALTRO MATERIALE A RICHIESTA

OTHER MATERIAL ON REQUEST / ANDERER WERKSTOFF AUF ANFRAGE

COME ORDINARE

How to order / Bestellbeispiel

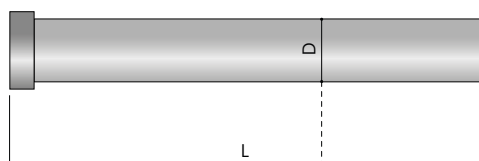

Qty	Type	Material	D	L
10	T1.3RB	M2	16	100

ALTERAZIONI

Alteration / Spezifikation

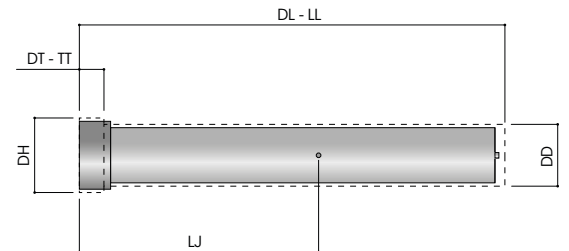

SPECIFICHE ALTERAZIONI A PAGINA 6

ALTERATION 6 PAGE / SPEZIFIKATION AUF SEITE 6

T1.3 PUNZONE ISO 8020 A/E

T1.3 PUNCH ISO 8020

T1.3 SCHNEIDSTEMPEL ISO 8020

CODE	D	H	T	40	50	56	60	63	70	71	80	90	100	120
T1.3RI/T1.3JI	3	5	3	•	•	•	•	•	•	•	•	•	•	•
	4	6	3	•	•	•	•	•	•	•	•	•	•	•
T1.3RB	3	6	5	•	•	•	•	•	•	•	•	•	•	•
	4	7	5	•	•	•	•	•	•	•	•	•	•	•
T1.3RB/T1.3JB	5	8	5	•	•	•	•	•	•	•	•	•	•	•
	6	9	5		•	•	•	•	•	•	•	•	•	•
	8	11	5		•	•	•	•	•	•	•	•	•	•
	10	13	5		•	•	•	•	•	•	•	•	•	•
	13	16	5		•	•	•	•	•	•	•	•	•	•
	20	23	5		•	•	•	•	•	•	•	•	•	•
T1.3RI/T1.3JI	25	28	5		•	•	•	•	•	•	•	•	•	•
	32	35	5					•	•	•	•	•	•	•
	20	24	5			•		•		•	•		•	
	25	29	5			•		•		•	•		•	
	32	36	5					•		•	•		•	

T1.3 PUNZONE ISO 8020 B/F RIBASSATO

T1.3 PUNCH ISO 8020, STEPPED

T1.3 SCHNEIDSTEMPEL ISO 8020, ABGESETZT

T1.3R

Punzone ISO 8020 B
Punch ISO 8020 B
Schneidstempel ISO 8020 B

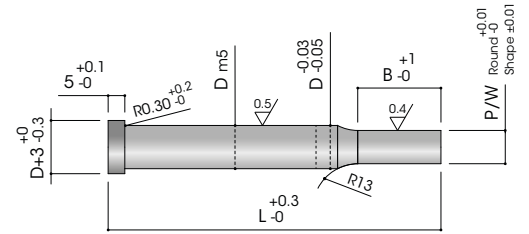

T1.3J

Punzone ISO 8020 F con espulsore
Punch ISO 8020 F with ejector
Schneidstempel ISO 8020 F mit Abdrückstift

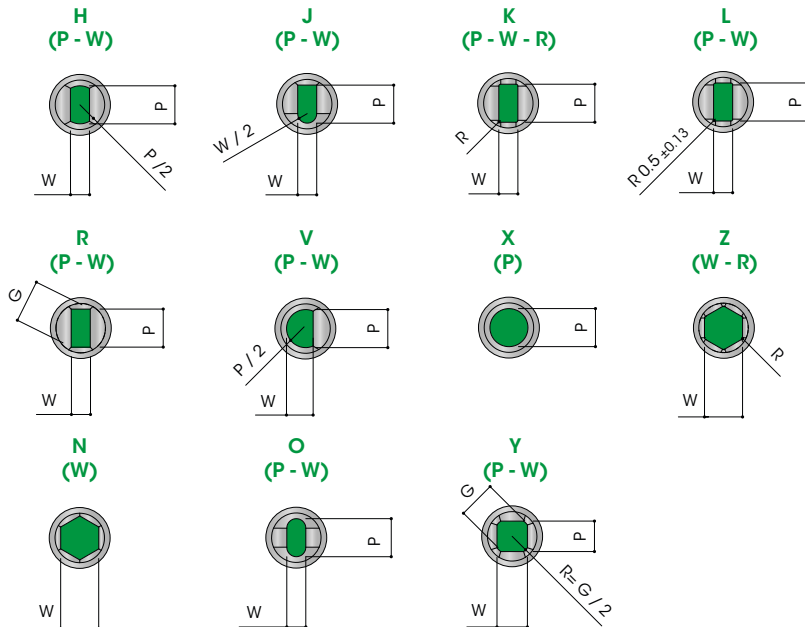
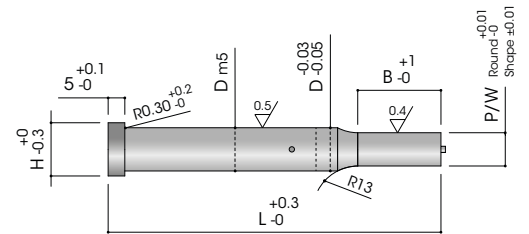

MATERIALI

Material / Werkstoff

CODE	DESCRIPTION	BODY HARDNESS	HEAD HARDNESS
A2	HWS / 1.2436	60-63 HRC	40-45 HRC
M2	HSS / 1.3343	62-64 HRC	50-53 HRC
PS	ASP23	63-65 HRC	50-53 HRC

ALTRO MATERIALE A RICHIESTA

OTHER MATERIAL ON REQUEST / ANDERER WERKSTOFF AUF ANFRAGE

COME ORDINARE

How to order / Bestellbeispiel

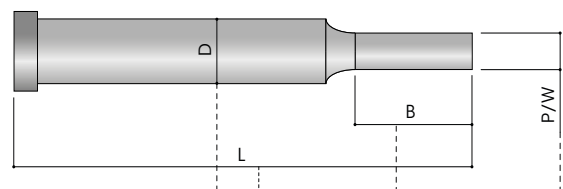

Q.ty	Type	Material	D	L	Dim. Shape	B	Key Flat	Alteration
10	T1.3RX	M2	16	100	P12.5	B22	K2	DL98

T1.3 PUNZONE ISO 8020 B/F RIBASSATO

T1.3 PUNCH ISO 8020, STEPPED

T1.3 SCHNEIDSTEMPEL ISO 8020, ABGESETZT

CODE	D	RANGE P	RANGE B	MIN W	MAX P/G	40	50	56	60	63	70	71	80	90	100	120	150
T1.3R	3	1 ÷ 2.99	8 ÷ 19	1	2.95	*	*	*	*	*	*	*	*	*	*	*	*
	4	1.6 ÷ 3.99	8 ÷ 19	1.6	3.95	*	*	*	*	*	*	*	*	*	*	*	*
	5	1.6 ÷ 4.99	8 ÷ 19	1.6	4.95	*	*	*	*	*	*	*	*	*	*	*	*
	6	1.6 ÷ 5.99	13 ÷ 25	1.6	5.95	*	*	*	*	*	*	*	*	*	*	*	*
	8	2.5 ÷ 7.99	13 ÷ 25	2.5	7.95	*	*	*	*	*	*	*	*	*	*	*	*
	10	3.2 ÷ 9.99	13 ÷ 25	3.2	9.95	*	*	*	*	*	*	*	*	*	*	*	*
	13	5 ÷ 12.99	13 ÷ 25	4.5	12.95	*	*	*	*	*	*	*	*	*	*	*	*
	16	8 ÷ 15.99	13 ÷ 25	6	15.95	*	*	*	*	*	*	*	*	*	*	*	*
T1.3R/T1.3J	20	10 ÷ 19.99	19 ÷ 30	8	19.95	*	*	*	*	*	*	*	*	*	*	*	*
	25	12 ÷ 24.99	19 ÷ 30	9	24.95	*	*	*	*	*	*	*	*	*	*	*	*
	32	16 ÷ 31.99	19 ÷ 30	10	31.95	*	*	*	*	*	*	*	*	*	*	*	*
	38	18 ÷ 37.99	25 ÷ 35	6	37.95	*	*	*	*	*	*	*	*	*	*	*	*
	40	20 ÷ 39.99	25 ÷ 35	8	39.95	*	*	*	*	*	*	*	*	*	*	*	*
	45	25 ÷ 44.99	25 ÷ 35	9	44.95	*	*	*	*	*	*	*	*	*	*	*	*
	50	30 ÷ 49.99	25 ÷ 35	10	49.95	*	*	*	*	*	*	*	*	*	*	*	*
	56	35 ÷ 55.99	25 ÷ 35	11	55.95	*	*	*	*	*	*	*	*	*	*	*	*
	63	40 ÷ 62.99	25 ÷ 35	12	62.95	*	*	*	*	*	*	*	*	*	*	*	*

PIANI DI ORIENTAMENTO

Key flat / Verdrehsicherungen

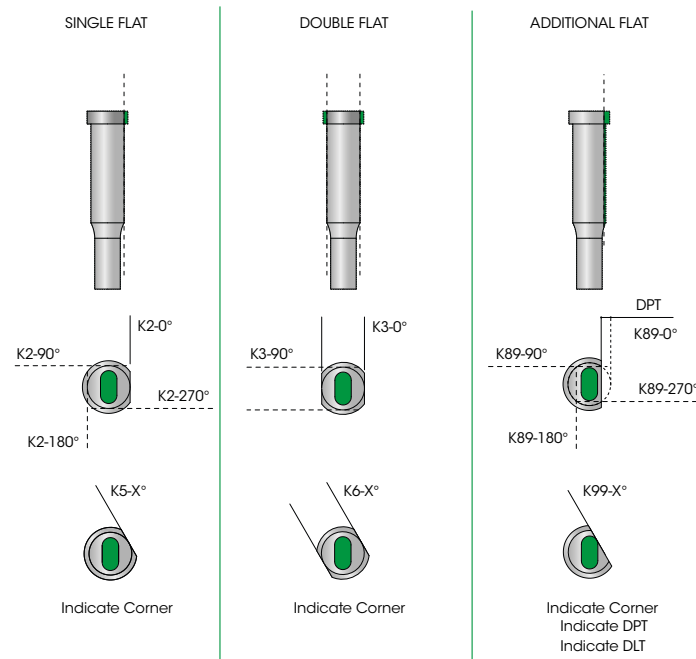

ALTERAZIONI

Alteration / Spezifikation

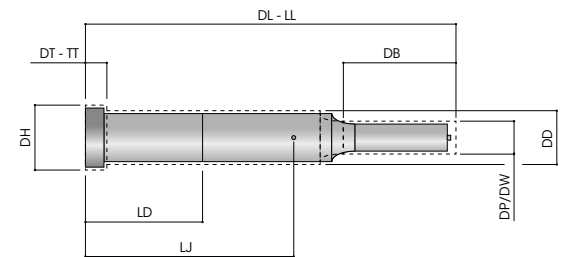

SPECIFICHE ALTERAZIONI A PAGINA 6
ALTERATION 6 PAGE / SPEZIFIKATION AUF SEITE 6

T1.4 PUNZONE A COLLO DI TROMBONE

T1.4 PUNCH WITH TAPERED

T1.4 SCHNEIDSTEMPEL MIT POSAUNENHALS

T1.4RB

Punzone a collo di trombone
Punch with tapered
Schneidstempel mit Posaunenhal

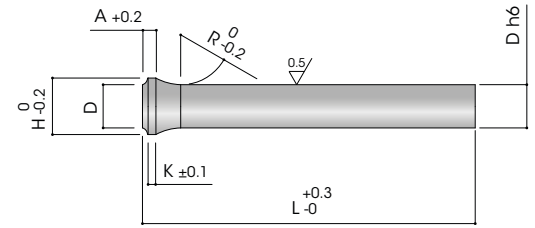

T1.4JB

Punzone a collo di trombone con espulsore
Punch with tapered with ejector
Schneidstempel mit Posaunenhal mit Abdrückstift

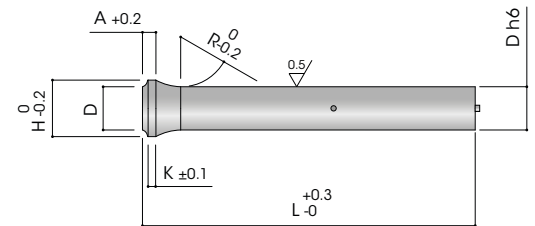

Esecuzione: Rettificato e lappato
Execution: Shaft is grinded and lapped
Ausführung: Schaft, geschliffen und geläppt

MATERIALI

Material / Werkstoff

CODE	DESCRIPTION	BODY HARDNESS	HEAD HARDNESS
M2	HSS / 1.3343	62-64 HRC	50-53 HRC
PS	ASP23	63-65 HRC	50-53 HRC

ALTRO MATERIALE A RICHIESTA
OTHER MATERIAL ON REQUEST / ANDERER WERKSTOFF AUF ANFRAGE

COME ORDINARE

How to order / Bestellbeispiel

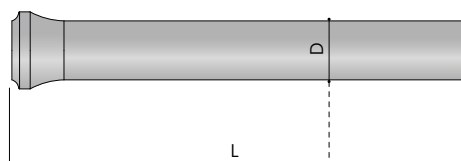

Qty	Type	Material	D	L
10	T1.4RB	M2	16	100

ALTERAZIONI

Alteration / Spezifikation

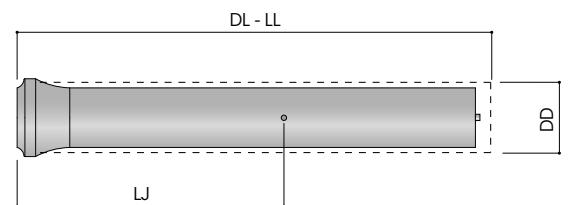

SPECIFICHE ALTERAZIONI A PAGINA 6
ALTERATION 6 PAGE / SPEZIFIKATION AUF SEITE 6

T1.4 PUNZONE A COLLO DI TROMBONE

T1.4 PUNCH WITH TAPERED

T1.4 SCHNEIDSTEMPEL MIT POSAUNENHALS

D	H	K	A	R	63	71	80	100	120
2	3	1	3	3.5	•	•	•	•	
2.1 ÷ 2.2	3.2	1	3	5	•	•	•	•	
2.3 ÷ 2.5	3.5	1	3	5	•	•	•	•	
2.6 ÷ 2.9	4	1	3	6.5	•	•	•	•	
3 ÷ 3.4	4.5	1	3	6.5	•	•	•	•	•
3.5 ÷ 3.9	5	1	3	8	•	•	•	•	•
4 ÷ 4.4	5.5	1.5	4	8	•	•	•	•	•
4.5 ÷ 4.9	6	1.5	4	8	•	•	•	•	•
5 ÷ 5.4	7	1.5	4	10	•	•	•	•	•
5.5 ÷ 5.9	8	1.5	4	10	•	•	•	•	•
6 ÷ 6.4	9	1.5	4	10	•	•	•	•	•
6.5 ÷ 7.4	10	1.5	4	12	•	•	•	•	•
7.5 ÷ 8.4	11	1.5	4	12	•	•	•	•	•
8.5 ÷ 9.4	13	1.5	4	15	•	•	•	•	•
9.5 ÷ 10.4	14	1.5	4	15	•	•	•	•	•
10.5 ÷ 11.4	15	1.5	4	15	•	•	•	•	•
11.5 ÷ 12.4	16	1.5	4	15	•	•	•	•	•
12.5 ÷ 13.4	17	1.5	4	15		•	•	•	•
13.5 ÷ 14.4	18	1.5	4	15		•	•	•	•
14.5 ÷ 15.4	19	1.5	4	15		•	•	•	•
15.5 ÷ 16.4	20	1.5	4	15		•	•	•	•
16.5 ÷ 17.4	21	1.5	4	15		•	•	•	•
17.5 ÷ 18.4	22	1.5	4	15		•	•	•	•
18.5 ÷ 19.4	23	1.5	4	15		•	•	•	•
19.5 ÷ 20	25	1.5	4	15		•	•	•	•
20.1 ÷ 20.9	26	1.5	4	15		•	•	•	•
21 ÷ 21.9	27	1.5	4	15		•	•	•	•
22 ÷ 22.9	28	1.5	4	15		•	•	•	•
23 ÷ 23.9	29	1.5	4	15		•	•	•	•
24 ÷ 24.9	30	1.5	4	15		•	•	•	•
25	31	1.5	4	15		•	•	•	•

T1.4 PUNZONE A COLLO DI TROMBONE RIBASSATO

T1.4 PUNCH WITH TAPERED, STEPPED

T1.4 SCHNEIDSTEMPEL MIT POSAUNENHALS, ABGESETZT

T1.4R

Punzone a collo di trombone
Punch with tapered
Schneidstempel mit Posaunenhal

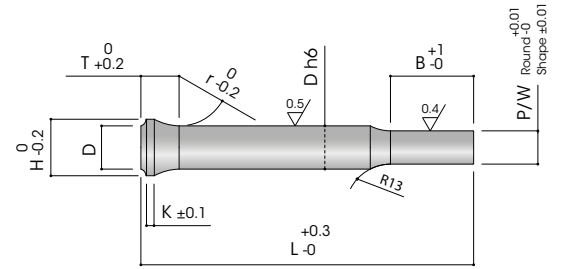

T1.4J

Punzone a collo di trombone con espulsore
Punch with tapered with ejector
Schneidstempel mit Posaunenhal mit Abdrückstift

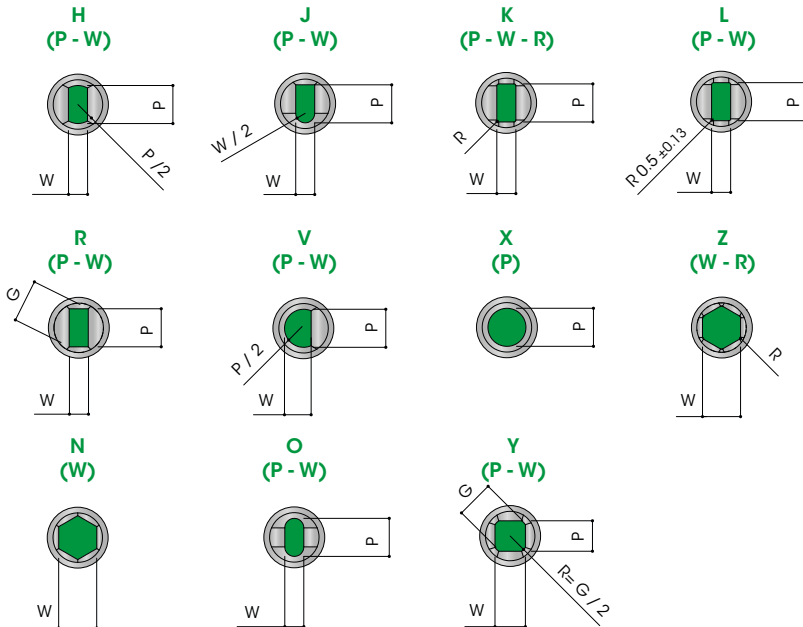
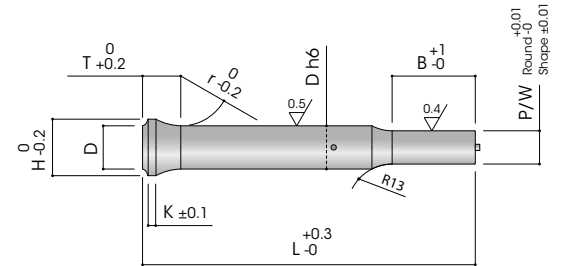

MATERIALI

Material / Werkstoff

CODE	DESCRIPTION	BODY HARDNESS	HEAD HARDNESS
M2	HSS / 1.3343	62-64 HRC	50-53 HRC
PS	ASP23	63-65 HRC	50-53 HRC

ALTRO MATERIALE A RICHIESTA
OTHER MATERIAL ON REQUEST / ANDERER WERKSTOFF AUF ANFRAGE

COME ORDINARE

How to order / Bestellbeispiel

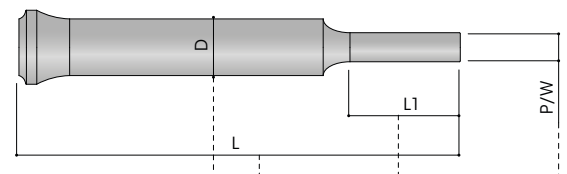

Qty	Type	Material	D	L	Dim. Shape	B	Key Flat	Alteration
10	T1.4RX	M2	16	100	P12.5	B22	K2	DL98

T1.4 PUNZONE A COLLO DI TROMBONE RIBASSATO

T1.4 PUNCH WITH TAPERED, STEPPED

T1.4 SCHNEIDSTEMPEL MIT POSAUNENHALS, ABGESETZT

CODE	D	H	K	A	R	RANGE P	RANGE B	MIN W	MAX P/G	40	50	56	60	63	70	71	80	90	100	120
T1.4R	3	4.5	1	3	6.5	1.00 ÷ 2.99	8 ÷ 19	1.00	2.95	*	*	*	*	*	*	*	*	*	*	*
	4	5.5	1.5	4	8	1.00 ÷ 3.99	8 ÷ 19	1.60	3.95	*	*	*	*	*	*	*	*	*	*	*
	5	7	1.5	4	10	1.60 ÷ 4.99	8 ÷ 19	1.60	4.95	*	*	*	*	*	*	*	*	*	*	*
	6	9	1.5	4	10	1.60 ÷ 5.99	13 ÷ 25	1.60	5.95	*	*	*	*	*	*	*	*	*	*	*
	7	10	1.5	4	12	2.50 ÷ 6.99	13 ÷ 25	2.50	6.95	*	*	*	*	*	*	*	*	*	*	*
	8	11	1.5	4	12	2.50 ÷ 7.99	13 ÷ 25	2.50	7.95	*	*	*	*	*	*	*	*	*	*	*
	9	13	1.5	4	15	3.20 ÷ 8.99	13 ÷ 25	3.20	8.95	*	*	*	*	*	*	*	*	*	*	*
	10	14	1.5	4	15	3.20 ÷ 9.99	13 ÷ 25	3.20	9.95	*	*	*	*	*	*	*	*	*	*	*
	11	15	1.5	4	15	4.00 ÷ 10.99	13 ÷ 25	4.00	10.95	*	*	*	*	*	*	*	*	*	*	*
	12	16	1.5	4	15	4.00 ÷ 11.99	13 ÷ 25	4.00	11.95	*	*	*	*	*	*	*	*	*	*	*
	T1.4R/ T1.4J	13	17	1.5	4	15	4.50 ÷ 12.99	13 ÷ 25	4.50	12.95	*	*	*	*	*	*	*	*	*	*
14		18	1.5	4	15	4.50 ÷ 13.99	13 ÷ 25	4.50	13.95	*	*	*	*	*	*	*	*	*	*	*
15		19	1.5	4	15	8.00 ÷ 14.99	13 ÷ 25	6.00	14.95	*	*	*	*	*	*	*	*	*	*	*
16		20	1.5	4	15	8.00 ÷ 15.99	13 ÷ 25	6.00	15.95	*	*	*	*	*	*	*	*	*	*	*
17		21	1.5	4	15	9.00 ÷ 16.99	19 ÷ 30	7.00	16.95	*	*	*	*	*	*	*	*	*	*	*
18		22	1.5	4	15	9.00 ÷ 17.99	19 ÷ 30	7.00	17.95	*	*	*	*	*	*	*	*	*	*	*
19		23	1.5	4	15	10.00 ÷ 18.99	19 ÷ 30	8.00	18.95	*	*	*	*	*	*	*	*	*	*	*
20		25	1.5	4	15	10.00 ÷ 19.99	19 ÷ 30	8.00	19.95	*	*	*	*	*	*	*	*	*	*	*
25		31	1.5	4	15	12.00 ÷ 24.99	19 ÷ 30	9.00	24.95	*	*	*	*	*	*	*	*	*	*	*

PIANI DI ORIENTAMENTO

Key flat / Verdrehsicherungen

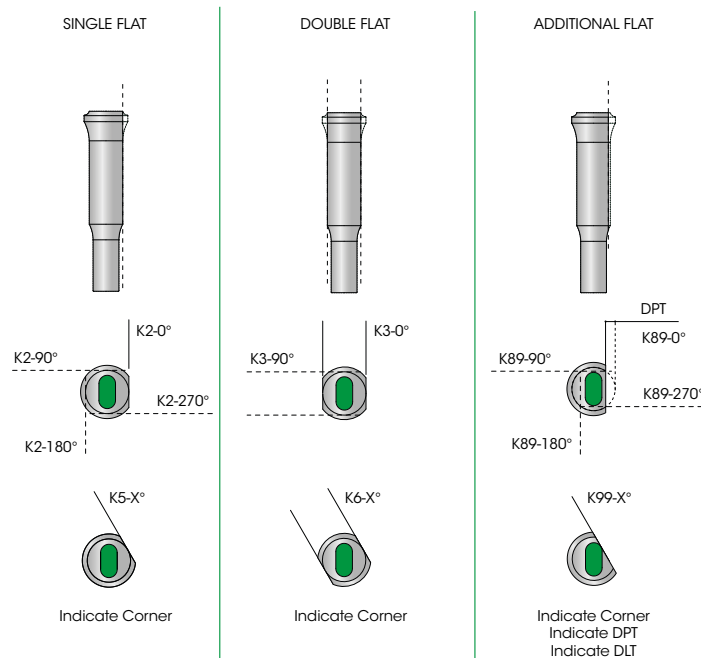

ALTERAZIONI

Alteration / Spezifikation

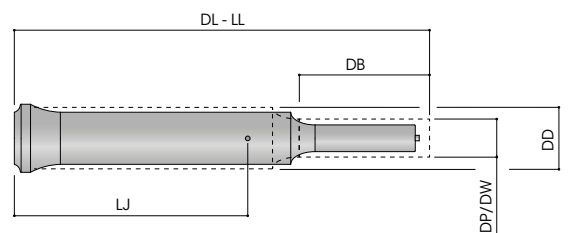

SPECIFICHE ALTERAZIONI A PAGINA 6
ALTERATION 6 PAGE / SPEZIFIKATION AUF SEITE 6

T1.5 PUNZONE TP

T1.5 PUNCH TP

T1.5 SCHNEIDSTEMPEL TP

T1.5RB

Punzone TP
Punch TP
Schneidstempel TP

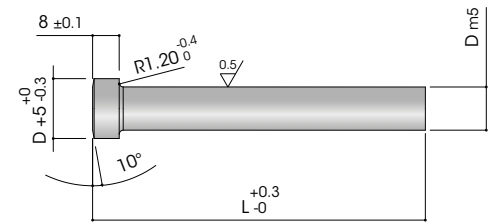

T1.5JB

Punzone TP con espulsore
Punch TP with ejector
Schneidstempel TP mit Abdrückstift

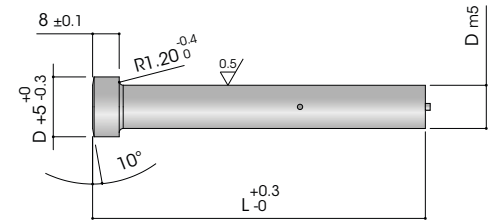

Esecuzione: Rettificato e lappato
Execution: Shaft is grinded and lapped
Ausführung: Schaft, geschliffen und geläpft

MATERIALI

Material / Werkstoff

CODE	DESCRIPTION	BODY HARDNESS	HEAD HARDNESS
M2	HSS / 1.3343	62-64 HRC	50-53 HRC
PS	ASP23	63-65 HRC	50-53 HRC

ALTRO MATERIALE A RICHIESTA
OTHER MATERIAL ON REQUEST / ANDERER WERKSTOFF AUF ANFRAGE

ALTERAZIONI

Alteration / Spezifikation

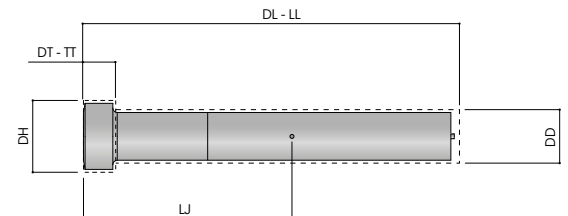

SPECIFICHE ALTERAZIONI A PAGINA 6
ALTERATION 6 PAGE / SPEZIFIKATION AUF SEITE 6

COME ORDINARE

How to order / Bestellbeispiel

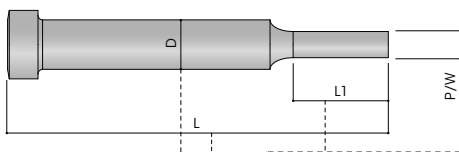

Qty 10 Type T1.5RX Material M2 D 16 L 100 Dim. Shape P12.5 B B22 Key Flat K2 Alteration DL98

T1.5 PUNZONE TP

T1.5 PUNCH TP

T1.5 SCHNEIDSTEMPEL TP

CODE	D	50	56	60	63	70	71	80	90	100	120
T1.5R/T1.5J	8	•	•	•	•	•	•	•	•	•	•
	10	•	•	•	•	•	•	•	•	•	•
	13	•	•	•	•	•	•	•	•	•	•
	16	•	•	•	•	•	•	•	•	•	•
	20	•	•	•	•	•	•	•	•	•	•
	25	•	•	•	•	•	•	•	•	•	•
	32	•	•	•	•	•	•	•	•	•	•

T1.5 PUNZONE TP RIBASSATO

T1.5 PUNCH TP, STEPPED

T1.5 SCHNEIDSTEMPEL TP, ABGESETZT

T1.5R

Punzone TP
Punch TP
Schneidstempel TP

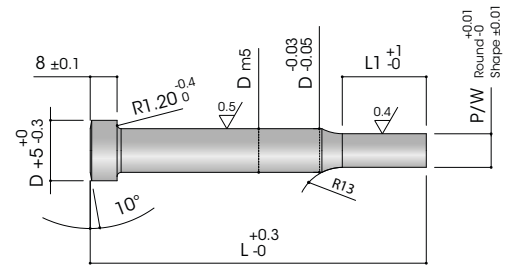

T1.5J

Punzone TP con espulsore
Punch TP with ejector
Schneidstempel TP mit Abdrückstift

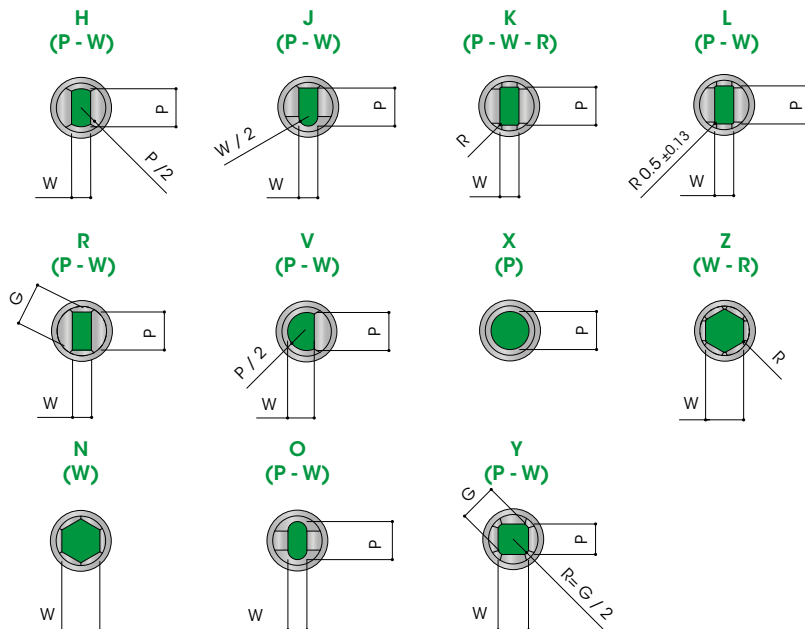
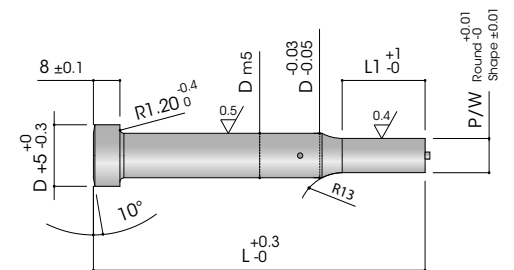

MATERIALI

Material / Werkstoff

CODE	DESCRIPTION	BODY HARDNESS	HEAD HARDNESS
M2	HSS / 1.3343	62-64 HRC	50-53 HRC
PS	ASP23	63-65 HRC	50-53 HRC

ALTRO MATERIALE A RICHIESTA

OTHER MATERIAL ON REQUEST / ANDERER WERKSTOFF AUF ANFRAGE

COME ORDINARE

How to order / Bestellbeispiel

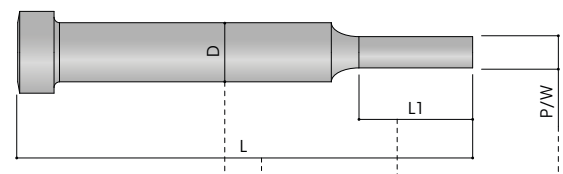

Qty	Type	Material	D	L	Dim. Shape	B	Key Flat	Alteration
10	T1.5RX	M2	16	100	P12.5	B22	K2	DL98

T1.5 PUNZONE TP RIBASSATO

T1.5 PUNCH TP, STEPPED

T1.5 SCHNEIDSTEMPEL TP, ABGESETZT

CODE	D	RANGE P	RANGE B	MIN W	MAX P/G	50	56	60	63	70	71	80	90	100	120
T1.5R/T1.5J	8	2.5 ÷ 7.99	13 ÷ 25	2.5	7.95	*	*	*	*	*	*	*	*	*	*
	10	3.2 ÷ 9.99	13 ÷ 25	3.2	9.95	*	*	*	*	*	*	*	*	*	*
	13	5 ÷ 12.99	13 ÷ 25	4.5	12.95	*	*	*	*	*	*	*	*	*	*
	16	8 ÷ 15.99	13 ÷ 25	6	15.95	*	*	*	*	*	*	*	*	*	*
	20	10 ÷ 19.99	19 ÷ 30	8	19.95	*	*	*	*	*	*	*	*	*	*
	25	12 ÷ 24.99	19 ÷ 30	9	24.95	*	*	*	*	*	*	*	*	*	*
	32	16 ÷ 31.99	19 ÷ 30	10	31.95	*	*	*	*	*	*	*	*	*	*

PIANI DI ORIENTAMENTO

Key flat / Verdrehsicherungen

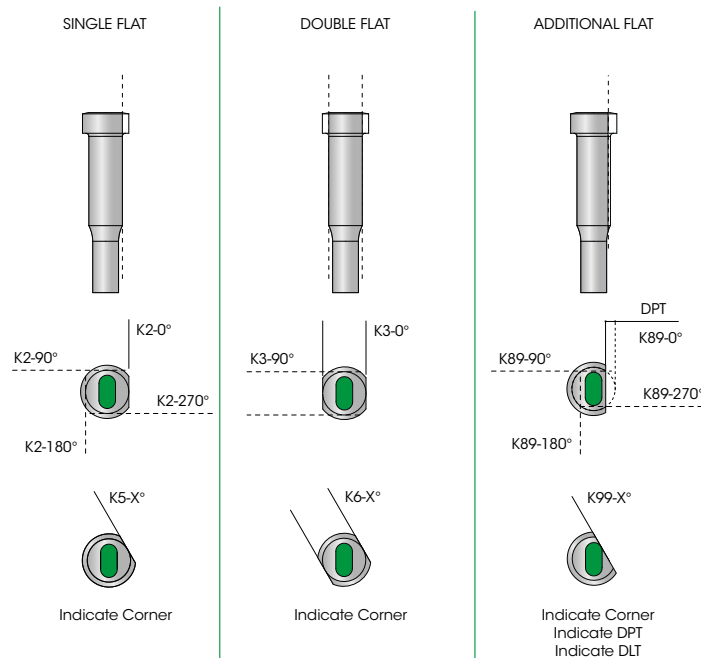

ALTERAZIONI

Alteration / Spezifikation

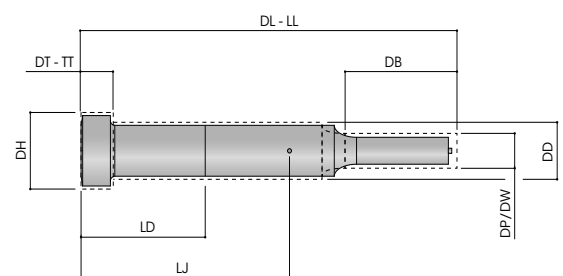

SPECIFICHE ALTERAZIONI A PAGINA 6
ALTERATION 6 PAGE / SPEZIFIKATION AUF SEITE 6

T9 PORTAPUNZONE

T9 RETAINER

T9 AUFNAHMEPLATTE

T9.3RT

Portapunzone
Retainer
Aufnahmeplatte

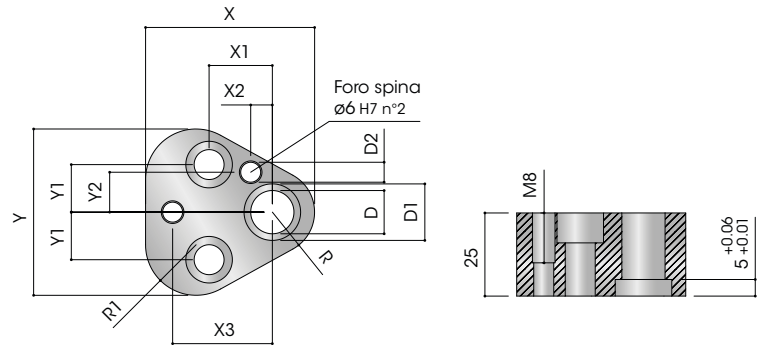

T9.3RT S

Portapunzone
Retainer
Aufnahmeplatte mit Verdrehschutz

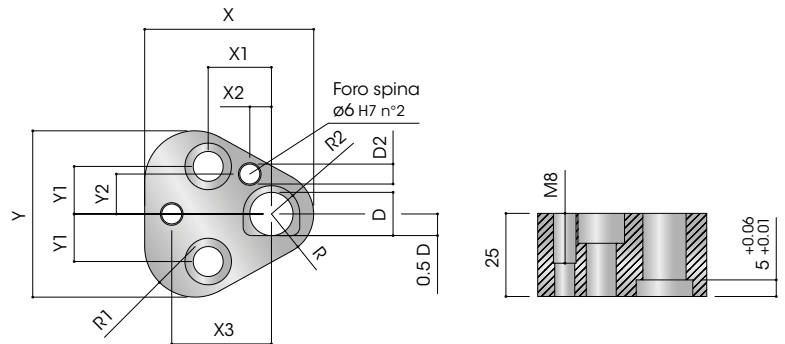

CODE	D	X	Y	X1	X2	X3	Y1	Y2	D1	SCREW	R	R1
10	44,5	43,7	19	7,5	26,925	11,1	9	14	M8	9,5	12	
13	50,8	50	19	6,5	29,97	14,3	12	17	M8	12,7	15,2	
16	54	53,2	19	6	31,75	15,9	13,5	20	M8	14,3	16,8	
20	60,3	59,5	19	5	33,53	17,5	16,5	24	M10	17,5	20	
25	69,9	69,1	23,8	7	40,64	19,8	22	29	M12	22,2	24,7	
32	69,9	69,1	23,8	7	40,64	19,8	22	36	M12	22,2	24,7	

T9 PORTAPUNZONE

T9 RETAINER

T9 AUFNAHMEPLATTE

T9.30T

Portapunzone
Retainer
Aufnahmeplatte

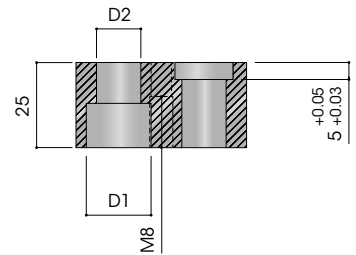
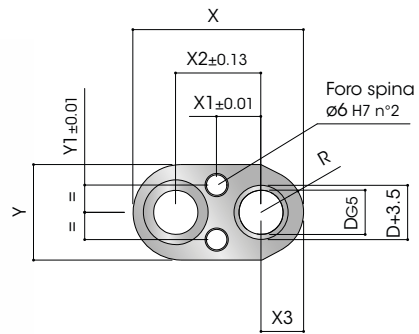

T9.30T S

Portapunzone
Retainer
Aufnahmeplatte mit Verdrehschutz

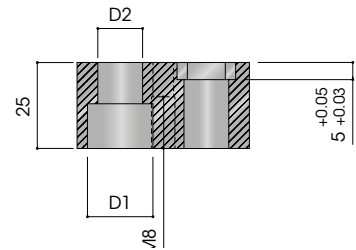
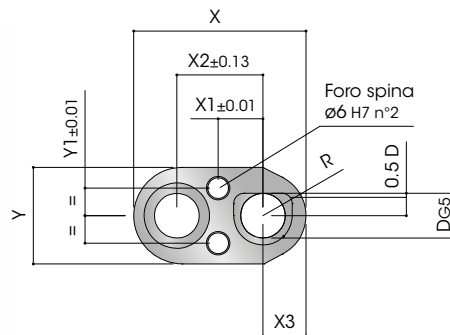

CODE	D	X	Y	X1	X2	X3	Y1	D1	D2	SCREW	R
10	47	28	13	25	9.5	8	19	13	M12	9.5	
13	50	28	13	25	12.5	8	19	13	M12	12.5	
16	52	32	13	25	14	8	19	13	M12	14	
20	55	35	14	25	17.5	11	19	13	M12	17.5	
25	73	44	20	35	22	15	25	17	M16	22	
32	73	50	20	35	22	15	25	17	M16	22	

T930T/T930TS

T9 PIASTRINE DI REAZIONE

T9 SHIM PLATE

T9 DRUCKPLATTE

T9.3UR

Piastrina di reazione
Shim plate
Druckplatte

Material: SK4, TEMPERED
Hardness: 56-60 HRC

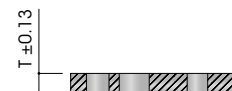
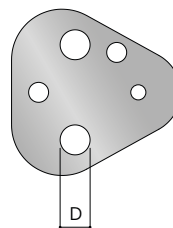

CODE	D	T
T93UR.1018	10	1,8
T93UR.1048	10	4,8
T93UR.1318	13	1,8
T93UR.1348	13	4,8
T93UR.1618	16	1,8
T93UR.1648	16	4,8

CODE	D	T
T93UR.2018	20	1,8
T93UR.2048	20	4,8
T93UR.2518	25	1,8
T93UR.2518	25	4,8
T93UR.3218	32	1,8
T93UR.3248	32	4,8

T9.3UO

Piastrina di reazione
Shim plate
Druckplatte

Material: SK4, TEMPERED
Hardness: 56-60 HRC

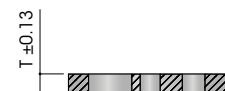
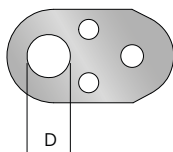

CODE	D	T
T93UO.1018	10	1,8
T93UO.1048	10	4,8
T93UO.1318	13	1,8
T93UO.1348	13	4,8
T93UO.1618	16	1,8
T93UO.1648	16	4,8

CODE	D	T
T93UO.2018	20	1,8
T93UO.2048	20	4,8
T93UO.2518	25	1,8
T93UO.2518	25	4,8
T93UO.3218	32	1,8
T93UO.3248	32	4,8





T7.1101 STARK-STRIP CON COVER PER PUNZONI CON TESTA CILINDRICA ISO 8020

T7.1101 STARK-STRIP WITH COVER FOR HEAD PUNCHES ISO 8020

T7.1101 STARK-STRIP MIT SCHUTZHÜLLE FÜR LOCHSTEMPEL MIT ZYLINDRISCHEM KOPF ISO 8020

T7.1101

Modello Strip
Strip Model
Modell

Esempio di ordine / Example of order / Bestellbeispiel:
T7.1101. [0010]

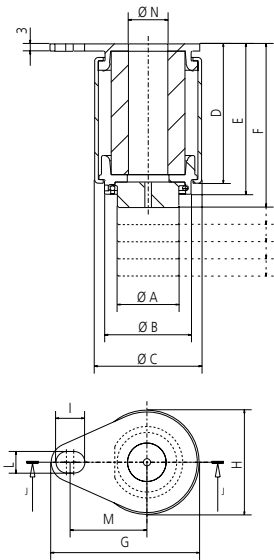

T7.8058

Testina sbazzata
Blank head
Vorgeschliffener Kopf

Esempio di ordine / Example of order / Bestellbeispiel:
T7.8058. [1010]. [001]

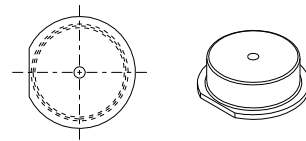

Testina Antirotazione / Sagome su richiesta
Anti-rotation System / Shapes upon request
Kopf mit Verdrehschutz
/ Diese Profile werden auf Anfrage gefertigt

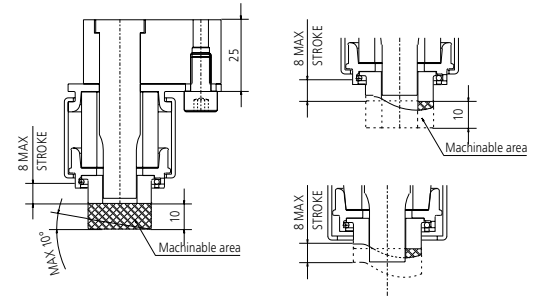
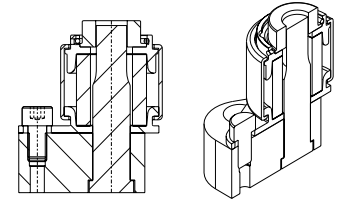

TESTINA

Head / Köpfe

Per togliere la testina rimuovere il seeger come indicato.
To extract the stripper head, remove the seeger as indicated.
Zur Entfernung des Kopfes lösen Sie wie angeführt den Sprengring ab.

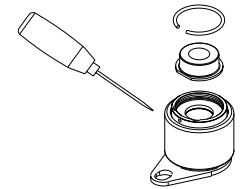

F

MODELLO MODEL MODELL	Ø PUNZONE PUNCH LOCHSTEMPEL	Ø A	Ø B	Ø C	D	E	Pun. L = 70/71	Pun. L = 80	Pun. L = 90	Pun. L = 100	G	H	I	L	M	Ø N	MAX STROKE	MAX FORCE (daN)
T7.1101.0010	10	16	25	33	37	40.5	47	56	66	76	51.5	33	12	9	26.925	10.1	8	200
T7.1101.0013	13	20	34	42	37	41	47	56	66	76	59	42	12	9	30	13.1	8	350
T7.1101.0016	16	25	39	47.5	37	41	47	56	66	76	63.5	47.5	12	9	31.75	16.1	8	400
T7.1101.0020	20	35	45.5	53	37	41.5	47	56	66	76	68	53	12	9	33.5	20.1	8	600
T7.1101.0025	25	44	57.5	67	37	42	47	56	66	76	82	67	12	9	40.65	25.1	8	900
T7.1101.0032	32	44	57.5	67	37	42	47	56	66	76	82	67	12	9	40.65	32.1	8	750
T7.1101.0040	40	48	65	73.5	37	42.5	47	56	66	76	88.5	73.5	12	9	44	40.1	8	750

COMBINAZIONI D'ORDINE STARK-STRIP + TESTINE PAG. 36

Order schemes Stark-Strip + Heads (page 36) / Mögliche Bestellkombinationen Stark-Strip + Köpfe (seite 36)

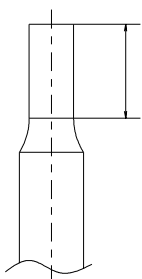

19=8058.....002
25=8058.....001

Ø	LUNGHEZZA PUNZONE PUNCH'S LENGTH LOCHSTEMPELLÄNGE	TESTA CILINDRICA / HEADED PUNCHES / ZYLINDRISCHEM KOPF			
		70/71	80	90	100
10		T7.1101.0010 + T7.8058.1010	T7.1101.0010 + T7.8058.1020	T7.1101.0010 + T7.8058.1030	T7.1101.0010 + T7.8058.1040
13		T7.1101.0013 + T7.8058.1310	T7.1101.0013 + T7.8058.1320	T7.1101.0013 + T7.8058.1330	T7.1101.0013 + T7.8058.1340
16		T7.1101.0016 + T7.8058.1610	T7.1101.0016 + T7.8058.1620	T7.1101.0016 + T7.8058.1630	T7.1101.0016 + T7.8058.1640
20		T7.1101.0020 + T7.8058.2010	T7.1101.0020 + T7.8058.2020	T7.1101.0020 + T7.8058.2030	T7.1101.0020 + T7.8058.2040
25		T7.1101.0025 + T7.8058.2510	T7.1101.0025 + T7.8058.2520	T7.1101.0025 + T7.8058.2530	T7.1101.0025 + T7.8058.2540
32		T7.1101.0032 + T7.8058.3210	T7.1101.0032 + T7.8058.3220	T7.1101.0032 + T7.8058.3230	T7.1101.0032 + T7.8058.3240
40		T7.1101.0040 + T7.8058.4010	T7.1101.0040 + T7.8058.4020	T7.1101.0040 + T7.8058.4030	T7.1101.0040 + T7.8058.4040

T7.1101 STARK-STRIP CON COVER PER PUNZONI BALL LOCK LIGHT DUTY

T7.1101 STARK-STRIP WITH COVER FOR BALL LOCK PUNCHES LIGHT DUTY

T7.1101 STARK-STRIP MIT SCHUTZHÜLLE FÜR LOCHSTEMPEL BALL LOCK LIGHT DUTY

T7.1101

Modello Strip
Strip Model
Modell

Esempio di ordine / Example of order / Bestellbeispiel:
T7.1101. [0010]

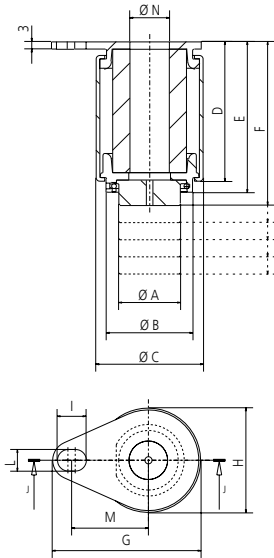

T7.8058

Testina sbazzata
Blank head
Vorgeschliffener Kopf

Esempio di ordine / Example of order / Bestellbeispiel:
T7.8058. [1010]. [001]

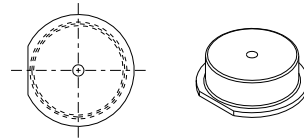
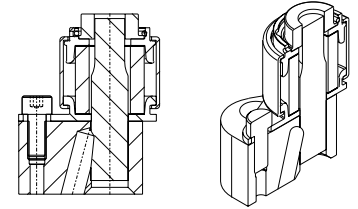

Testina Antirrotazione / Sagome su richiesta
Anti-rotation System / Shapes upon request
Kopf mit Verdrehschutz
/ Diese Profile werden auf Anfrage gefertigt

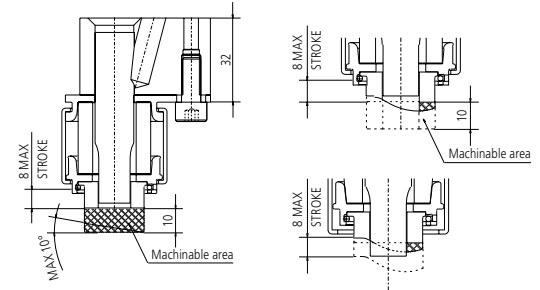

TESTINA

Head / Köpfe

Per togliere la testina rimuovere il seeger come indicato.
To extract the stripper head, remove the seeger as indicated.
Zur Entfernung des Kopfes lösen Sie wie angeführt den Sprengring ab.

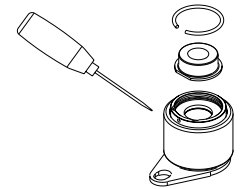

F

MODELLO MODEL MODELL	Ø PUNZONE PUNCH LOCHSTEMPEL	Ø A	Ø B	Ø C	D	E	Pun. L = 70/71	Pun. L = 80	Pun. L = 90	Pun. L = 100	G	H	I	L	M	Ø N	MAX STROKE	MAX FORCE (daN)
T7.1101.0010	10	16	25	33	37	40.5	47	56	66	76	51	33	12	9	26.925	10.1	8	200
T7.1101.0013	13	20	34	42	37	41	47	56	66	76	59	42	12	9	30	13.1	8	350
T7.1101.0016	16	25	39	47.5	37	41	47	56	66	76	63.5	47.5	12	9	31.75	16.1	8	400
T7.1101.0020	20	35	45.5	53	37	41.5	47	56	66	76	68	53	12	9	33.5	20.1	8	600
T7.1101.0025	25	44	57.5	67	37	42	47	56	66	76	82	67	12	9	40.65	25.1	8	900
T7.1101.0032	32	44	57.5	67	37	42	47	56	66	76	82	67	12	9	40.65	32.1	8	750
T7.1101.0040	40	48	65	73.5	37	42.5	47	56	66	76	88.5	73.5	12	9	44	40.1	8	750

COMBINAZIONI D'ORDINE STARK-STRIP + TESTINE PAG. 36

Order schemes Stark-Strip + Heads (page 36) / Mögliche Bestellkombinationen Stark-Strip + Köpfe (seite 36)

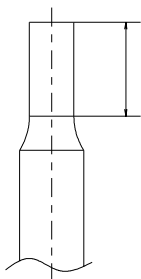

19=8058..... .002
25=8058..... .001

Ø	LUNGHEZZA PUNZONE PUNCH'S LENGTH LOCHSTEMPELLÄNGE	BALL LOCK LIGHT DUTY			
		70/71	80	90	100
10		T7.1101.0010 + T7.8058.1010	T7.1101.0010 + T7.8058.1020	T7.1101.0010 + T7.8058.1030	T7.1101.0010 + T7.8058.1040
13		T7.1101.0013 + T7.8058.1310	T7.1101.0013 + T7.8058.1320	T7.1101.0013 + T7.8058.1330	T7.1101.0013 + T7.8058.1340
16		T7.1101.0016 + T7.8058.1610	T7.1101.0016 + T7.8058.1620	T7.1101.0016 + T7.8058.1630	T7.1101.0016 + T7.8058.1640
20		T7.1101.0020 + T7.8058.2010	T7.1101.0020 + T7.8058.2020	T7.1101.0020 + T7.8058.2030	T7.1101.0020 + T7.8058.2040
25		T7.1101.0025 + T7.8058.2510	T7.1101.0025 + T7.8058.2520	T7.1101.0025 + T7.8058.2530	T7.1101.0025 + T7.8058.2540
32		T7.1101.0032 + T7.8058.3210	T7.1101.0032 + T7.8058.3220	T7.1101.0032 + T7.8058.3230	T7.1101.0032 + T7.8058.3240
40		T7.1101.0040 + T7.8058.4010	T7.1101.0040 + T7.8058.4020	T7.1101.0040 + T7.8058.4030	T7.1101.0040 + T7.8058.4040

T7.1101 STARK-STRIP CON COVER PER PUNZONI BALL LOCK HEAVY DUTY

T7.1101 STARK-STRIP WITH COVER FOR BALL LOCK PUNCHES HEAVY DUTY

T7.1101 STARK-STRIP MIT SCHUTZHÜLLE FÜR LOCHSTEMPEL BALL LOCK HEAVY DUTY

T7.1101

Modello Strip
Strip Model
Modell

Esempio di ordine / Example of order / Bestellbeispiel:
T7.1101. [0010]

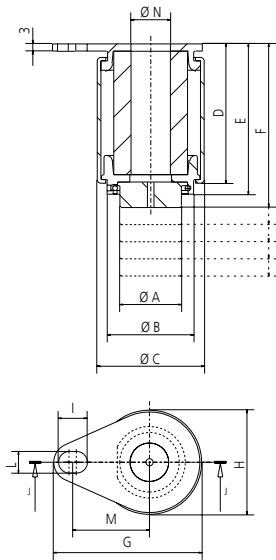

T7.8058

Testina sbazzata
Blank head
Vorgeschliffener Kopf

Esempio di ordine / Example of order / Bestellbeispiel:
T7.8058. [1010]. [001]

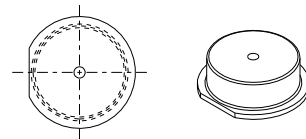
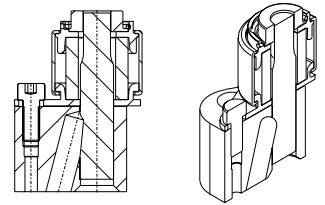

Testina Antirotazione / Sagome su richiesta
Anti-rotation System / Shapes upon request
Kopf mit Verdrehschutz
/ Diese Profile werden auf Anfrage gefertigt

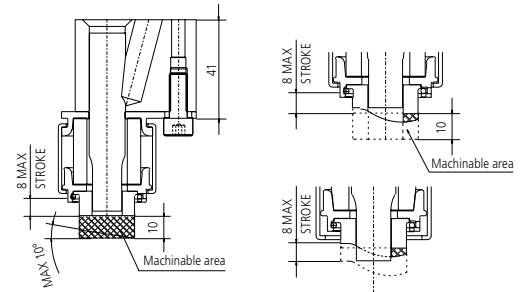

TESTINA

Head / Köpfe

Per togliere la testina rimuovere il seeger come indicato.
To extract the stripper head, remove the seeger as indicated.
Zur Entfernung des Kopfes lösen Sie wie angeführt den Sprengring ab.

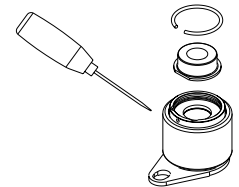

F

MODELLO MODEL MODELL	Ø PUNZONE PUNCH LOCHSTEMPEL	Ø A	Ø B	Ø C	D	E	Pun. L = 80	Pun. L = 90	Pun. L = 100	G	H	I	L	M	Ø N	MAX STROKE	MAX FORCE (daN)
T7.1101.0010	10	16	25	33	37	40.5	47	56	66	51.5	33	12	9	26.925	10.1	8	200
T7.1101.0013	13	20	34	42	37	41	47	56	66	59	42	12	9	30	13.1	8	350
T7.1101.0016	16	25	39	47.5	37	41	47	56	66	63.5	47.5	12	9	31.75	16.1	8	400
T7.1101.0020	20	35	45.5	53	37	41.5	47	56	66	68	53	12	9	33.5	20.1	8	600
T7.1101.0025	25	44	57.5	67	37	42	47	56	66	82	67	12	9	40.65	25.1	8	900
T7.1101.0032	32	44	57.5	67	37	42	47	56	66	82	67	12	9	40.65	32.1	8	750
T7.1101.0040	40	48	65	73.5	37	42.5	47	56	66	88.5	73.5	12	9	44	40.1	8	750

COMBINAZIONI D'ORDINE STARK-STRIP + TESTINE PAG. 36

Order schemes Stark-Strip + Heads (page 36) / Mögliche Bestellkombinationen Stark-Strip + Köpfe (seite 36)

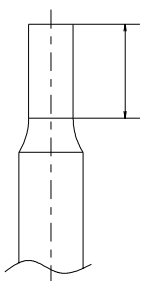

19=8058.....002
25=8058.....001

Ø	LUNGHEZZA PUNZONE PUNCH'S LENGTH LOCHSTEMPELLÄNGE	BALL LOCK HEAVY DUTY			
		70/71	80	90	100
10	/	T7.1101.0010 + T7.8058.1010	T7.1101.0010 + T7.8058.1020	T7.1101.0010 + T7.8058.1030	
13	/	T7.1101.0013 + T7.8058.1310	T7.1101.0013 + T7.8058.1320	T7.1101.0013 + T7.8058.1330	
16	/	T7.1101.0016 + T7.8058.1610	T7.1101.0016 + T7.8058.1620	T7.1101.0016 + T7.8058.1630	
20	/	T7.1101.0020 + T7.8058.2010	T7.1101.0020 + T7.8058.2020	T7.1101.0020 + T7.8058.2030	
25	/	T7.1101.0025 + T7.8058.2510	T7.1101.0025 + T7.8058.2520	T7.1101.0025 + T7.8058.2530	
32	/	T7.1101.0032 + T7.8058.3210	T7.1101.0032 + T7.8058.3220	T7.1101.0032 + T7.8058.3230	
40	/	T7.1101.0040 + T7.8058.4010	T7.1101.0040 + T7.8058.4020	T7.1101.0040 + T7.8058.4030	

TESTINA SBOZZATA

BLANK HEAD

ABSTREIFER

T7.8058

Testina sbozzata
Blank head
Vorgeschliffener Kopf

Esempio di ordine / Example of order / Bestellbeispiel:
T7.8058. [1010]. [001]

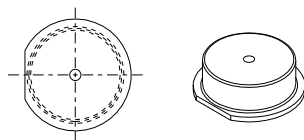

Testina Antirrotazione / Sagome su richiesta
Anti-rotation System / Shapes upon request
Kopf mit Verdrehschutz
/ Diese Profile werden auf Anfrage gefertigt

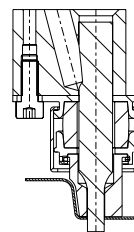

1101....

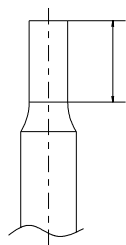

19=8058.....002
25=8058.....001

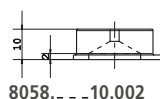

8058...10.002

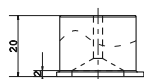

8058...20.001

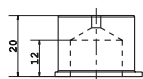

8058...20.002

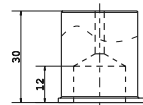

8058...30.001

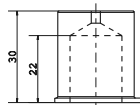

8058...30.002

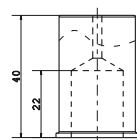

8058...40.001

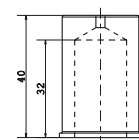

8058...40.002

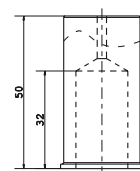

8058...50.002

Luce per lato: 0,15 mm
Clearance: 0,15 mm
Pssung + 0,15 mm je Seite

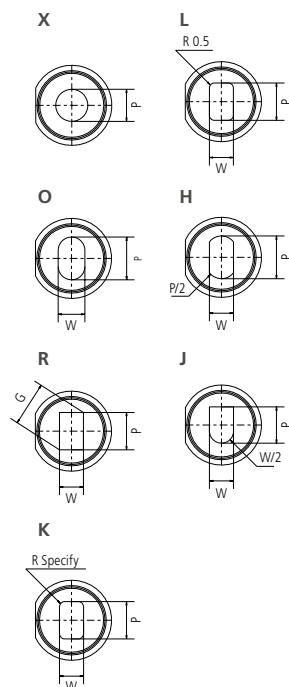

MODELLO TESTINA

Head Model / Modell Köpfe

Ø	LUNGHEZZA PUNZONE PUNCH'S LENGTH LOCHSTEMPELLÄNGE	TESTA CILINDRICA / HEADED PUNCHES / ZYLINDRISCHEM KOPF			
		70/71	80	90	100
10		T7.1101.0010 + T7.8058.1010	T7.1101.0010 + T7.8058.1020	T7.1101.0010 + T7.8058.1030	T7.1101.0010 + T7.8058.1040
13		T7.1101.0013 + T7.8058.1310	T7.1101.0013 + T7.8058.1320	T7.1101.0013 + T7.8058.1330	T7.1101.0013 + T7.8058.1340
16		T7.1101.0016 + T7.8058.1610	T7.1101.0016 + T7.8058.1620	T7.1101.0016 + T7.8058.1630	T7.1101.0016 + T7.8058.1640
20		T7.1101.0020 + T7.8058.2010	T7.1101.0020 + T7.8058.2020	T7.1101.0020 + T7.8058.2030	T7.1101.0020 + T7.8058.2040
25		T7.1101.0025 + T7.8058.2510	T7.1101.0025 + T7.8058.2520	T7.1101.0025 + T7.8058.2530	T7.1101.0025 + T7.8058.2540
32		T7.1101.0032 + T7.8058.3210	T7.1101.0032 + T7.8058.3220	T7.1101.0032 + T7.8058.3230	T7.1101.0032 + T7.8058.3240
40		T7.1101.0040 + T7.8058.4010	T7.1101.0040 + T7.8058.4020	T7.1101.0040 + T7.8058.4030	T7.1101.0040 + T7.8058.4040

Ø	LUNGHEZZA PUNZONE PUNCH'S LENGTH LOCHSTEMPELLÄNGE	BALL LOCK LIGHT DUTY			
		70/71	80	90	100
10		T7.1101.0010 + T7.8058.1010	T7.1101.0010 + T7.8058.1020	T7.1101.0010 + T7.8058.1030	T7.1101.0010 + T7.8058.1040
13		T7.1101.0013 + T7.8058.1310	T7.1101.0013 + T7.8058.1320	T7.1101.0013 + T7.8058.1330	T7.1101.0013 + T7.8058.1340
16		T7.1101.0016 + T7.8058.1610	T7.1101.0016 + T7.8058.1620	T7.1101.0016 + T7.8058.1630	T7.1101.0016 + T7.8058.1640
20		T7.1101.0020 + T7.8058.2010	T7.1101.0020 + T7.8058.2020	T7.1101.0020 + T7.8058.2030	T7.1101.0020 + T7.8058.2040
25		T7.1101.0025 + T7.8058.2510	T7.1101.0025 + T7.8058.2520	T7.1101.0025 + T7.8058.2530	T7.1101.0025 + T7.8058.2540
32		T7.1101.0032 + T7.8058.3210	T7.1101.0032 + T7.8058.3220	T7.1101.0032 + T7.8058.3230	T7.1101.0032 + T7.8058.3240
40		T7.1101.0040 + T7.8058.4010	T7.1101.0040 + T7.8058.4020	T7.1101.0040 + T7.8058.4030	T7.1101.0040 + T7.8058.4040

Ø	LUNGHEZZA PUNZONE PUNCH'S LENGTH LOCHSTEMPELLÄNGE	BALL LOCK HEAVY DUTY			
		70/71	80	90	100
10		/	T7.1101.0010 + T7.8058.1010	T7.1101.0010 + T7.8058.1020	T7.1101.0010 + T7.8058.1030
13		/	T7.1101.0013 + T7.8058.1310	T7.1101.0013 + T7.8058.1320	T7.1101.0013 + T7.8058.1330
16		/	T7.1101.0016 + T7.8058.1610	T7.1101.0016 + T7.8058.1620	T7.1101.0016 + T7.8058.1630
20		/	T7.1101.0020 + T7.8058.2010	T7.1101.0020 + T7.8058.2020	T7.1101.0020 + T7.8058.2030
25		/	T7.1101.0025 + T7.8058.2510	T7.1101.0025 + T7.8058.2520	T7.1101.0025 + T7.8058.2530
32		/	T7.1101.0032 + T7.8058.3210	T7.1101.0032 + T7.8058.3220	T7.1101.0032 + T7.8058.3230
40		/	T7.1101.0040 + T7.8058.4010	T7.1101.0040 + T7.8058.4020	T7.1101.0040 + T7.8058.4030

Attenzione: per sagome speciali, è necessario un disegno 3D del cliente / Attention: In case of special shape, the customer's 3D drawing is necessary / Achtung: kundenspezifische Profile werden ausschließlich nach Vorlage einer 3D-Zeichnung gefertigt.

ACCESSORIO - MASCHERA PER LAVORAZIONE DELLA TESTINA

DEVICE - JIG FOR MACHINING THE STRIPPER HEAD

ZUBEHÖRE - BAUTEIL ZUR KOPFBEARBEITUNG

Accessorio - Maschera per lavorazione della testina

Device - Jig for machining the stripper head

Zeubehöre - Bauteil zur Kopfbearbeitung

MODELLO MODEL / MODELL	∅	PUNZONE PUNCH / LOCHSTEMPEL
T7.8061.0010		10
T7.8061.0013		13
T7.8061.0016		16
T7.8061.0020		20
T7.8061.0025		25
T7.8061.0032		32
T7.8061.0040		40

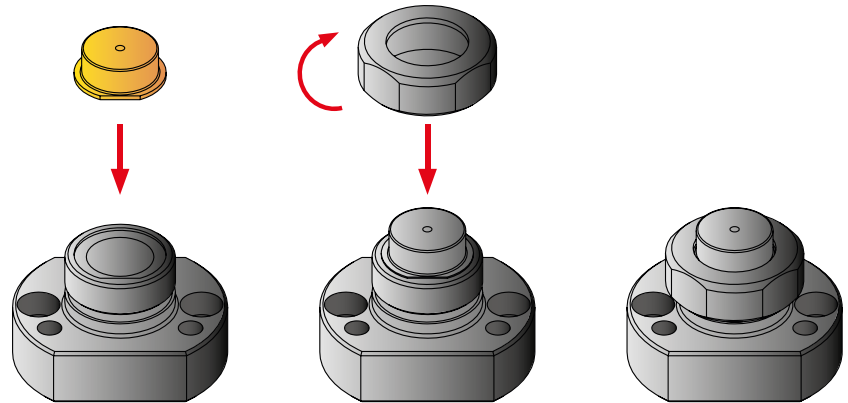

ATTENZIONE

Per sagomare la testina:

- rimuoverla dallo stripper
- inserirla nel dispositivo
- avvitare la ghiera di bloccaggio
- posizionare il dispositivo su macchina utensile, elettroerosione o stampo per eseguire la sagoma richiesta
- rimontare la testina

ACHTUNG

Zum Profilieren bitte wie folgt vorgehen:

- den Kopf vom Stripper entfernen
- den Kopf in die Vorrichtung einsetzen
- den Verriegelungsring festschrauben
- die Vorrichtung in die Werkzeugmaschine einbauen, Elektroerosion oder Werkzeug zum Profilieren
- den Kopf einbauen

ATTENTION

In order to shape the head:

- remove it from the stripper
- insert the head into the special device
- tighten the locking ring nut
- place the device on the machine stain, EDM or tool plate to perform the required shape
- put back together the head with the body

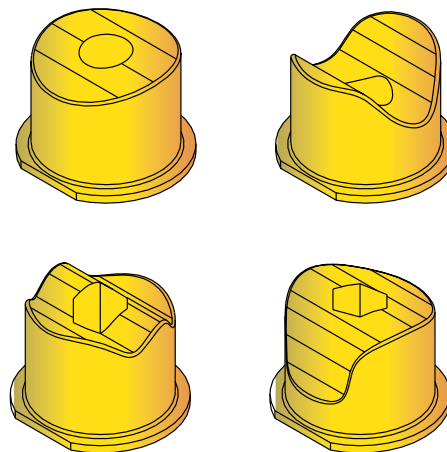

Esempi di testine speciali

Examples of special head / Beispiele von Kundenspezifischen Köpfen



T2.1 MATRICE DIN 9845 CON / SENZA TESTA

T2.1 MATRIX DIE DIN 9845 WITH / WITHOUT SHOULDER

T2.1 SCHNEIDBUCHSE DIN 9845 MIT / OHNE BUND

T2.103

Matrice DIN 9845 tipo "A" liscia
Matrix die DIN 9845 type "A" without head
Schneidbuchse DIN 9845 art "A" Bund

Material: A2(HWS) / M2(HSS)
Hardness: A2 60±2 HRC
M2 64±2 HRC

Execution: Hardening, tempered

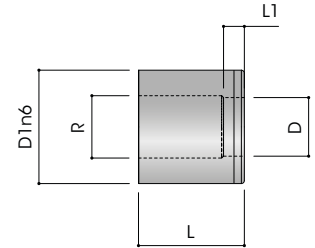

Esempio di ordine / Example of order / Bestellbeispiel:

T2.103 [MATERIAL].[D][L]E[D1] T2.103A2.060028E12

D	D1	L	L1	R
2	6	20	28	3
2 ÷ 3,3	7	20	28	3
3,1 ÷ 4	8	20	28	4
4,1 ÷ 5	10	20	28	4
5,1 ÷ 6	12	20	28	4
6,1 ÷ 8	15	20	28	4
8,1 ÷ 10	18	20	28	4

D	D1	L	L1	R
10,1 ÷ 12	22	20	28	5
12,1 ÷ 15	26	20	28	5
* 15,5 ÷ 18	30	20	28	5
* 18,5 ÷ 22	35	20	28	5
* 22,5 ÷ 26	42	20	28	5
* 26,5 ÷ 30	48	20	28	5

* INCREMENTO 0.5 MM. / INCREASE OF 0.5 MM. / ZUNAHME VON 0.5 MM.

T2.113

Matrice DIN 9845 tipo "B" con testa
Matrix die DIN 9845 type "B" with head
Schneidbuchse DIN 9845 art "B" mit kopf

Material: A2(HWS) / M2(HSS)
Hardness: A2 60±2 HRC
M2 64±2 HRC

Execution: Hardening, tempered

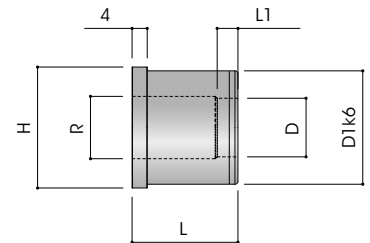

Esempio di ordine / Example of order / Bestellbeispiel:

T2.113 [MATERIAL].[D][L]E[D1] T2.113A2.060028E12

D	D1	H	L	L1	R
2	6	8	20	28	3
2 ÷ 3,3	7	9	20	28	3
3,1 ÷ 4	8	10	20	28	4
4,1 ÷ 5	10	12	20	28	4
5,1 ÷ 6	12	14	20	28	4
6,1 ÷ 8	15	17	20	28	4
8,1 ÷ 10	18	20	20	28	4

D	D1	H	L	L1	R
10,1 ÷ 12	22	24	20	28	5
12,1 ÷ 15	26	28	20	28	5
* 15,5 ÷ 18	30	32	20	28	5
* 18,5 ÷ 22	35	37	20	28	5
* 22,5 ÷ 26	42	44	20	28	5
* 26,5 ÷ 30	48	50	20	28	5

* INCREMENTO 0.5 MM. / INCREASE OF 0.5 MM. / ZUNAHME VON 0.5 MM.

T2.3 MATRICE ISO 8977 SENZA TESTA

T2.3 MATRIX DIE ISO 8977 WITHOUT SHOULDER

T2.3 SCHNEIDBUCHSE ISO 8977 OHNE BUND

T2.3D

Matrice liscia ISO 8977

Matrix Headless ISO 8977

Schneidbuchse Ohne Bund ISO 8977

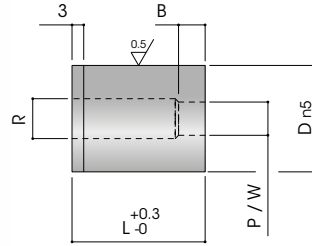

T2.3DE

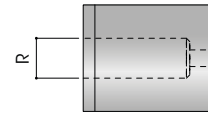

T2.3DU

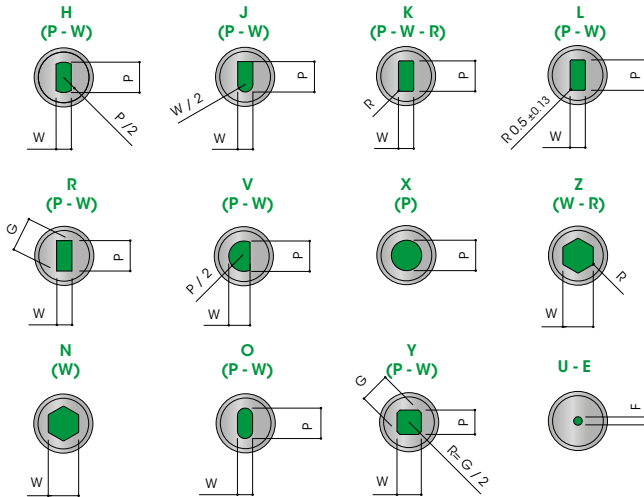
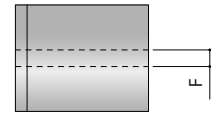

COME ORDINARE

How to order / Bestellbeispiel

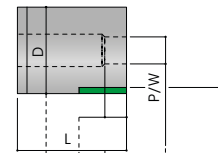

Type	Material	D	B	L	Dim. Shape	Key Flat	Alterazioni
T2.3DX	M2	25	S	28	P13.2	K80	DL26

MATERIALI

Material / Werkstoff

CODE	DESCRIPTION	BODY HARDNESS
A2	HWS / 1.2436	60-63 HRC
M2	HSS / 1.3343	62-64 HRC

PIANI DI ORIENTAMENTO

Key flat / Verdrehsicherungen

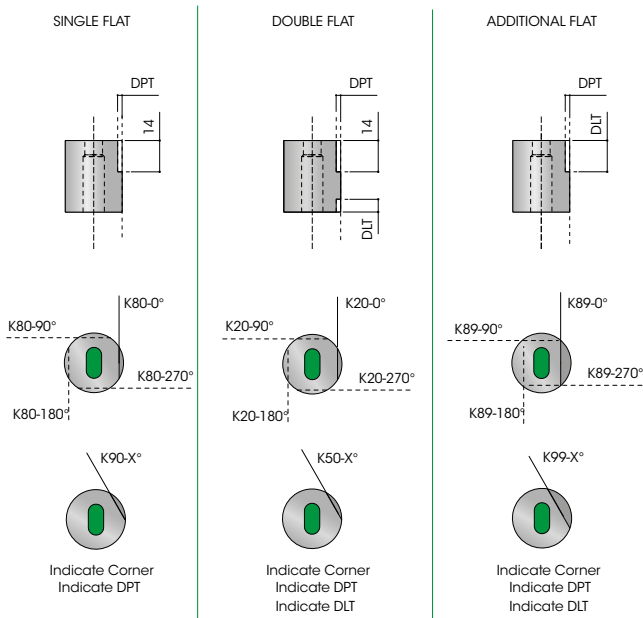

ALTRO MATERIALE A RICHIESTA

OTHER MATERIAL ON REQUEST / ANDERER WERKSTOFF AUF ANFRAGE

ALTERAZIONI

Alteration / Spezifikation

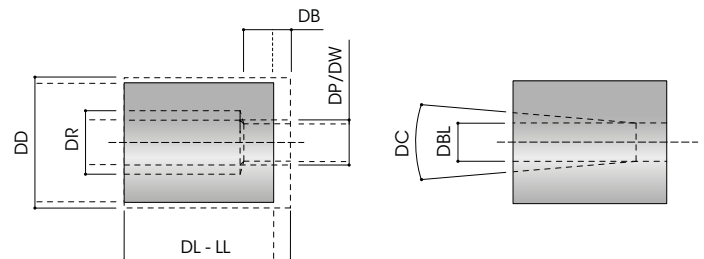

SPECIFICHE ALTERAZIONI A PAGINA 6

ALTERATION 6 PAGE / SPEZIFIKATION AUF SEITE 6

T2.3 MATRICE ISO 8977 SENZA TESTA

T2.3 MATRIX DIE ISO 8977 WITHOUT SHOULDER

T2.3 SCHNEIDBUCHSE ISO 8977 OHNE BUND

D	B			RANGE P	MIN W	MAX P/G	R	F	L							
	S	A	B						20	22	25	28	30	32	35	40
8	4	—	—	1.5 ÷ 2.4	—	—	3.5	0.8	*	*	*	*	*	*	*	*
8	4	—	—	2.41 ÷ 3	—	—	4	0.8	*	*	*	*	*	*	*	*
8	4	8	—	3.01 ÷ 3.2	—	—	4	0.8	*	*	*	*	*	*	*	*
10	4	—	—	1.5 ÷ 2.4	—	—	3.5	0.8	*	*	*	*	*	*	*	*
10	4	—	—	2.41 ÷ 3	—	—	4	0.8	*	*	*	*	*	*	*	*
10	4	8	—	3.01 ÷ 3.2	1.2	3.2	4	0.8	*	*	*	*	*	*	*	*
10	4	8	—	3.21 ÷ 3.5	1.2	5	6	0.8	*	*	*	*	*	*	*	*
13	5	—	—	1.5 ÷ 2.4	—	—	3.5	1.6	*	*	*	*	*	*	*	*
13	5	—	—	2.41 ÷ 3	—	—	4	1.6	*	*	*	*	*	*	*	*
13	5	8	—	3.01 ÷ 3.2	—	—	4	1.6	*	*	*	*	*	*	*	*
13	5	8	—	3.21 ÷ 3.5	2	5	6	1.6	*	*	*	*	*	*	*	*
13	5	8	—	5.01 ÷ 7.2	2	7.2	8	1.6	*	*	*	*	*	*	*	*
16	5	8	—	5 ÷ 7.2	2.4	7.2	8	1.6	*	*	*	*	*	*	*	*
16	5	8	—	7.21 ÷ 8.8	2.4	8.8	9.5	1.6	*	*	*	*	*	*	*	*
20	5	12	20	7 ÷ 8.8	3.2	8.8	9.5	1.6	*	*	*	*	*	*	*	*
20	5	12	20	8.81 ÷ 11	3.2	11	12	1.6	*	*	*	*	*	*	*	*
22	6	12	20	9 ÷ 14	4	14	15	1.6	*	*	*	*	*	*	*	*
25	6	12	20	11 ÷ 14	4.8	14	15	1.6	*	*	*	*	*	*	*	*
25	6	12	20	14.1 ÷ 16.5	4.8	16.5	17.5	1.6	*	*	*	*	*	*	*	*
32	6	12	20	13 ÷ 16.5	5.5	16.5	17.5	1.6	*	*	*	*	*	*	*	*
32	6	12	20	16.51 ÷ 20	5.5	20	21	1.6	*	*	*	*	*	*	*	*
38	8	12	20	16 ÷ 20	6.4	20	21	1.6	*	*	*	*	*	*	*	*
38	8	12	20	20.01 ÷ 26	6.4	26	27	1.6	*	*	*	*	*	*	*	*
40	8	12	20	16 ÷ 20	6.4	20	21	1.6	*	*	*	*	*	*	*	*
40	8	12	20	20.01 ÷ 26	6.4	26	27	1.6	*	*	*	*	*	*	*	*
45	8	12	20	19 ÷ 26	8	26	27	3.2	*	*	*	*	*	*	*	*
45	8	12	20	26.01 ÷ 35	8	35	35	3.2	*	*	*	*	*	*	*	*
50	8	12	20	22 ÷ 26	—	—	27	3.2	*	*	*	*	*	*	*	*
50	8	12	20	26.01 ÷ 35	9	35	36	3.2	*	*	*	*	*	*	*	*
50	8	12	20	35.01 ÷ 40	9	40	41	3.2	*	*	*	*	*	*	*	*
56	8	12	20	25 ÷ 35	10	35	36	3.2	*	*	*	*	*	*	*	*
56	8	12	20	35.01 ÷ 40	10	40	41	3.2	*	*	*	*	*	*	*	*
56	8	12	20	40.01 ÷ 45	10	45	46	3.2	*	*	*	*	*	*	*	*
63	8	12	20	28 ÷ 35	—	—	36	3.2	*	*	*	*	*	*	*	*
63	8	12	20	35.01 ÷ 40	11	40	41	3.2	*	*	*	*	*	*	*	*
63	8	12	20	40.01 ÷ 45	11	45	46	3.2	*	*	*	*	*	*	*	*
63	8	12	20	45.01 ÷ 50	11	50	51	3.2	*	*	*	*	*	*	*	*
71	8	12	20	31 ÷ 40	12	40	41	3.2	*	*	*	*	*	*	*	*
71	8	12	20	40.01 ÷ 45	12	40	46	3.2	*	*	*	*	*	*	*	*
71	8	12	20	45.01 ÷ 50	12	50	51	3.2	*	*	*	*	*	*	*	*
71	8	12	20	50.01 ÷ 56	12	56	57	3.2	*	*	*	*	*	*	*	*

Disponibili anche con diametro **76 / 85 / 90 / 100**

Also available with external diameter **76 / 85 / 90 / 100**

Auch mit einem Außendurchmesser **76 / 85 / 90 / 100**

T2.3 MATRICE ISO 8977 CON TESTA

T2.3 MATRIX DIE ISO 8977 WITH SHOULDER

T2.3 SCHNEIDBUCHSE ISO 8977 MIT BUND

T2.3H

Matrice con testa ISO 8977

Matrix Headed ISO 8977

Schneidbuchse mit Bund ISO 8977

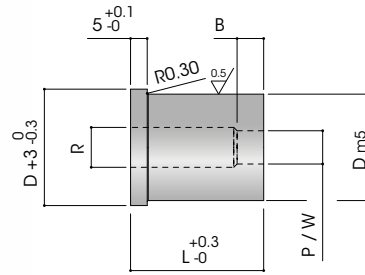

T2.3HE

T2.3HU

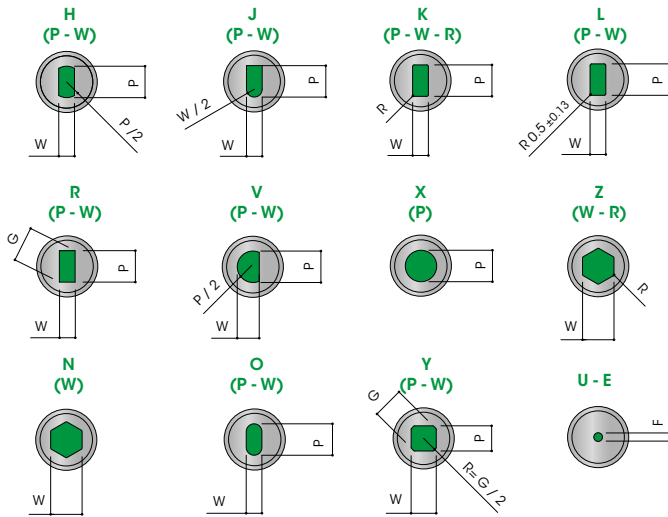
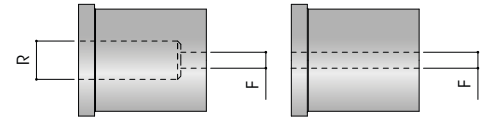

COME ORDINARE

How to order / Bestellbeispiel

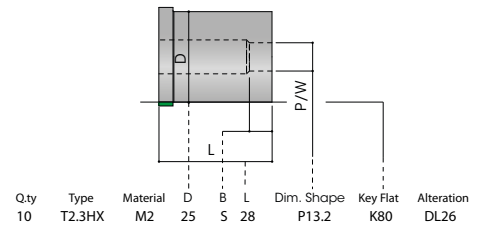

MATERIALI

Material / Werkstoff

CODE	DESCRIPTION	BODY HARDNESS
A2	HWS / 1.2436	60-63 HRC
M2	HSS / 1.3343	62-64 HRC

PIANI DI ORIENTAMENTO

Key flat / Verdrehsicherungen

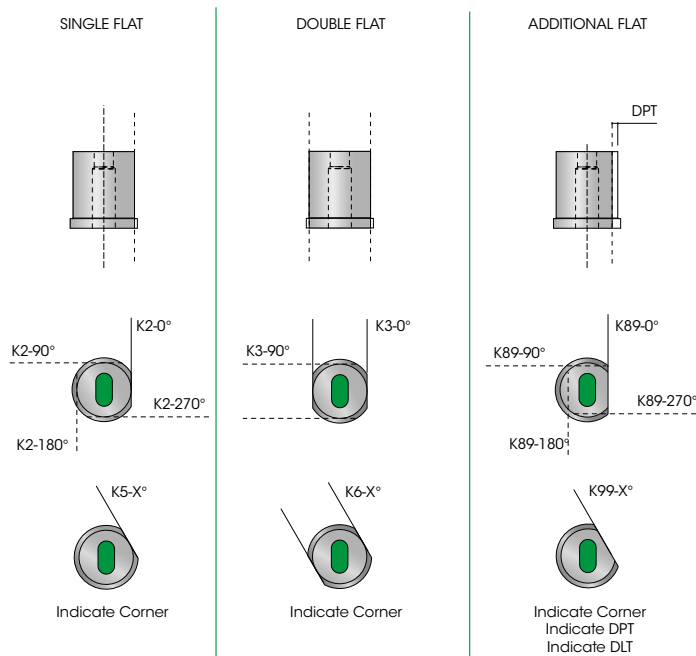

ALTRO MATERIALE A RICHIESTA

OTHER MATERIAL ON REQUEST / ANDERER WERKSTOFF AUF ANFRAGE

ALTERAZIONI

Alteration / Spezifikation

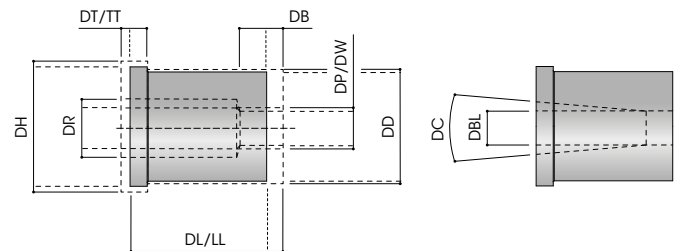

SPECIFICHE ALTERAZIONI A PAGINA 6

ALTERATION 6 PAGE / SPEZIFIKATION AUF SEITE 6

T2.3 MATRICE ISO 8977 CON TESTA

T2.3 MATRIX DIE ISO 8977 WITH SHOULDER

T2.3 SCHNEIDBUCHSE ISO 8977 OHNE BUND

D	B			RANGE P	MIN W	MAX P/G	R	F	L							
	S	A	B						20	22	25	28	30	32	35	40
8	4	—	—	1.5 ÷ 2.4	—	—	3.5	0.8	*	*	*	*	*	*	*	*
8	4	—	—	2.41 ÷ 3	—	—	4	0.8	*	*	*	*	*	*	*	*
8	4	8	—	3.01 ÷ 3.2	—	—	4	0.8	*	*	*	*	*	*	*	*
10	4	—	—	1.5 ÷ 2.4	—	—	3.5	0.8	*	*	*	*	*	*	*	*
10	4	—	—	2.41 ÷ 3	—	—	4	0.8	*	*	*	*	*	*	*	*
10	4	8	—	3.01 ÷ 3.2	1.2	3.2	4	0.8	*	*	*	*	*	*	*	*
10	4	8	—	3.21 ÷ 3.5	1.2	5	6	0.8	*	*	*	*	*	*	*	*
13	5	—	—	1.5 ÷ 2.4	—	—	3.5	1.6	*	*	*	*	*	*	*	*
13	5	—	—	2.41 ÷ 3	—	—	4	1.6	*	*	*	*	*	*	*	*
13	5	8	—	3.01 ÷ 3.2	—	—	4	1.6	*	*	*	*	*	*	*	*
13	5	8	—	3.21 ÷ 3.5	2	5	6	1.6	*	*	*	*	*	*	*	*
13	5	8	—	5.01 ÷ 7.2	2	7.2	8	1.6	*	*	*	*	*	*	*	*
16	5	8	—	5 ÷ 7.2	2.4	7.2	8	1.6	*	*	*	*	*	*	*	*
16	5	8	—	7.21 ÷ 8.8	2.4	8.8	9.5	1.6	*	*	*	*	*	*	*	*
20	5	12	20	7 ÷ 8.8	3.2	8.8	9.5	1.6	*	*	*	*	*	*	*	*
20	5	12	20	8.81 ÷ 11	3.2	11	12	1.6	*	*	*	*	*	*	*	*
22	6	12	20	9 ÷ 14	4	14	15	1.6	*	*	*	*	*	*	*	*
25	6	12	20	11 ÷ 14	4.8	14	15	1.6	*	*	*	*	*	*	*	*
25	6	12	20	14.1 ÷ 16.5	4.8	16.5	17.5	1.6	*	*	*	*	*	*	*	*
32	6	12	20	13 ÷ 16.5	5.5	16.5	17.5	1.6	*	*	*	*	*	*	*	*
32	6	12	20	16.51 ÷ 20	5.5	20	21	1.6	*	*	*	*	*	*	*	*
38	8	12	20	16 ÷ 20	6.4	20	21	1.6	*	*	*	*	*	*	*	*
38	8	12	20	20.01 ÷ 26	6.4	26	27	1.6	*	*	*	*	*	*	*	*
40	8	12	20	16 ÷ 20	6.4	20	21	1.6	*	*	*	*	*	*	*	*
40	8	12	20	20.01 ÷ 26	6.4	26	27	1.6	*	*	*	*	*	*	*	*
45	8	12	20	19 ÷ 26	8	26	27	3.2	*	*	*	*	*	*	*	*
45	8	12	20	26.01 ÷ 35	8	35	35	3.2	*	*	*	*	*	*	*	*
50	8	12	20	22 ÷ 26	—	—	27	3.2	*	*	*	*	*	*	*	*
50	8	12	20	26.01 ÷ 35	9	35	36	3.2	*	*	*	*	*	*	*	*
50	8	12	20	35.01 ÷ 40	9	40	41	3.2	*	*	*	*	*	*	*	*
56	8	12	20	25 ÷ 35	10	35	36	3.2	*	*	*	*	*	*	*	*
56	8	12	20	35.01 ÷ 40	10	40	41	3.2	*	*	*	*	*	*	*	*
56	8	12	20	40.01 ÷ 45	10	45	46	3.2	*	*	*	*	*	*	*	*
63	8	12	20	28 ÷ 35	—	—	36	3.2	*	*	*	*	*	*	*	*
63	8	12	20	35.01 ÷ 40	11	40	41	3.2	*	*	*	*	*	*	*	*
63	8	12	20	40.01 ÷ 45	11	45	46	3.2	*	*	*	*	*	*	*	*
63	8	12	20	45.01 ÷ 50	11	50	51	3.2	*	*	*	*	*	*	*	*
71	8	12	20	31 ÷ 40	12	40	41	3.2	*	*	*	*	*	*	*	*
71	8	12	20	40.01 ÷ 45	12	40	46	3.2	*	*	*	*	*	*	*	*
71	8	12	20	45.01 ÷ 50	12	50	51	3.2	*	*	*	*	*	*	*	*
71	8	12	20	50.01 ÷ 56	12	56	57	3.2	*	*	*	*	*	*	*	*

Disponibili anche con diametro **76 / 85 / 90 / 100**

Also available with external diameter **76 / 85 / 90 / 100**

Auch mit einem Außendurchmesser **76 / 85 / 90 / 100**

T4 PUNZONE MARCHIO

T4 STAMP

T4 BUCHSTABENSTEMPEL

T4.119.04

Punzone marchio
Stamp
Buchstabenstempel

Material: X153CrMoV12

Esempio di ordine / Example of order / Bestellbeispiel:
T411904. [CODE] T411904.A12105

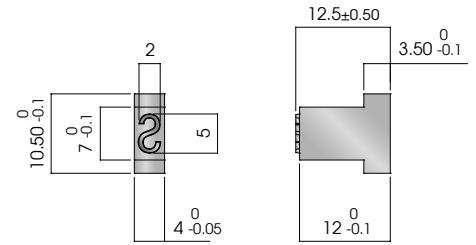

CODE	STAMP
T411904.012105	0
T411904.112105	1
T411904.212105	2
T411904.312105	3
T411904.412105	4
T411904.512105	5
T411904.612105	6/9
T411904.712105	7
T411904.812105	8
T411904.12105	SPACE

CODE	STAMP
T411904.A12105	A
T411904.B12105	B
T411904.C12105	C
T411904.D12105	D
T411904.E12105	E
T411904.F12105	F
T411904.G12105	G
T411904.H12105	H
T411904.I12105	I
T411904.J12105	J

CODE	STAMP
T411904.K12105	K
T411904.L12105	L
T411904.M12105	M
T411904.N12105	N
T411904.O12105	O
T411904.P12105	P
T411904.Q12105	Q
T411904.R12105	R
T411904.S12105	S
T411904.T12105	T

CODE	STAMP
T411904.U12105	U
T411904.V12105	V
T411904.W12105	W
T411904.X12105	X
T411904.Y12105	Y
T411904.Z12105	Z
T411904._12105	_
T411904..12105	.
T411904./12105	/
T411904.-12105	-

T4.119.02

Punzone marchio
Stamp
Buchstabenstempel

Material: X153CrMoV12

Esempio di ordine / Example of order / Bestellbeispiel:
T411902. [CODE] T411902.A12105

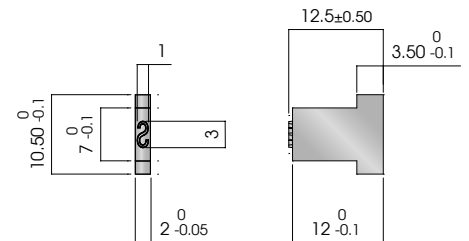

CODE	STAMP
T411902.012105	0
T411902.112105	1
T411902.212105	2
T411902.312105	3
T411902.412105	4
T411902.512105	5
T411902.612105	6/9
T411902.712105	7
T411902.812105	8
T411902.12105	SPACE

CODE	STAMP
T411902.A12105	A
T411902.B12105	B
T411902.C12105	C
T411902.D12105	D
T411902.E12105	E
T411902.F12105	F
T411902.G12105	G
T411902.H12105	H
T411902.I12105	I
T411902.J12105	J

CODE	STAMP
T411902.K12105	K
T411902.L12105	L
T411902.M12105	M
T411902.N12105	N
T411902.P12105	P
T411902.Q12105	Q
T411902.R12105	R
T411902.S12105	S
T411902.T12105	T
T411902.U12105	U

CODE	STAMP
T411902.V12105	V
T411902.W12105	W
T411902.X12105	X
T411902.Y12105	Y
T411902.Z12105	Z
T411902._12105	_
T411902..12105	.
T411902./12105	/
T411902.-12105	-

T4 PORTATIMBRI / REAZIONE

T4 RETAINER / BACKING PLATE

T4 HALTEPLATTE / DRUCKPLATTE

T4.219

Portatimbri
Stamp retainer
Halteplatte

Material: CK45

Esempio di ordine / Example of order / Bestellbeispiel:

T4.219[N.°STAMP][L]1518 T4.219.03.451518

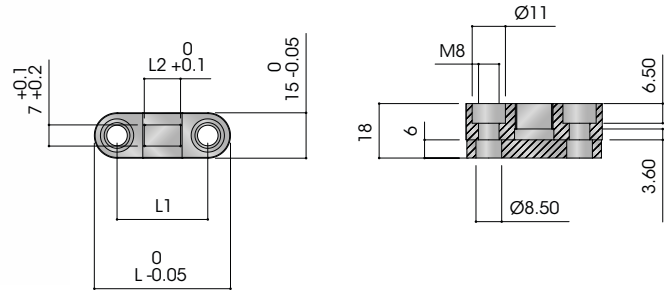

CODE	STAMP	L	L1	L2
T421903.451518	3	45	30	12
T421904.471518	4	47	32	16
T421906.551518	6	55	40	24

CODE	N° STAMP	L	L1	L2
T421908.631518	8	63	48	32
T421910.711518	10	71	56	40

T4.229

Piastra di reazione
Backing plate
Druckplatte

Material: CK45

Esempio di ordine / Example of order / Bestellbeispiel:

T4.229

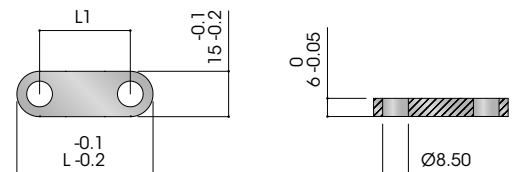

CODE	L	L1
T422945.451512	45	30
T422945.471512	47	32
T422945.551512	55	40

CODE	L	L1
T422945.631512	63	48
T422945.711512	71	56



T5.1 ESPULSORE DIN 9861

T5.1 EJECTOR PIN DIN 9861

T5.1 SCHNEIDSTEMPEL NACH DIN 9861

T5.102.0D

Espulsore DIN 9861-D DIN 1530-3

Ejector PIN DIN 9861-D DIN1530-3

Schneidstempel nach DIN 9861-D DIN 1530-3

Material: D2(1.2210)(WS)

Hardness SHANK: 60±2 HRC

Hardness HEAD: 45±5 HRC

Tolerance: g6

Execution: ground and lapped, the head is hot formed and tempered

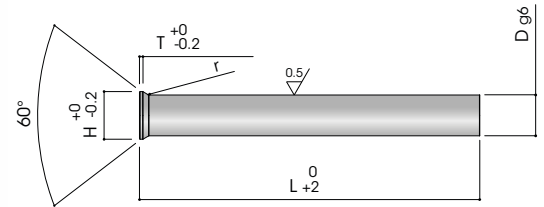

Esempio di ordine / Example of order / Bestellbeispiel:

T5.102.0D.[D][L] T5.102.0D.1250160

D	H	T	125	160	200	250	315
1 ÷ 1,1	1,8	0,5	•	•	•	•	
1,2 ÷ 1,3	2	0,5	•	•	•	•	
1,4 ÷ 1,5	2,2	0,5	•	•	•	•	
1,6 ÷ 1,7	2,5	0,5	•	•	•	•	
1,8 - 1,9	2,8	0,5	•	•	•	•	
2	3	0,5	•	•	•	•	
2,1 ÷ 2,2	3,2	0,5	•	•	•	•	
2,3 ÷ 2,5	3,5	0,5	•	•	•	•	
2,6 ÷ 2,9	4	0,5	•	•	•	•	
3 ÷ 3,4	4,5	0,5	•	•	•	•	
3,5 ÷ 3,9	5	0,5	•	•	•	•	
4 ÷ 4,4	5,5	0,5	•	•	•	•	•
4,5 ÷ 4,9	6	0,5	•	•	•	•	•
5 ÷ 5,4	6,5	0,5	•	•	•	•	•
5,5 ÷ 5,9	7	0,5	•	•	•	•	•
6 ÷ 6,4	8	0,5	•	•	•	•	•

D	H	T	125	160	200	250	315
6,5 ÷ 7,4	9	1	•	•	•	•	•
7,5 ÷ 8,4	10	1	•	•	•	•	•
8,5 ÷ 9,4	11	1	•	•	•	•	•
9,5 ÷ 10,4	12	1	•	•	•	•	•
10,5 ÷ 11,4	13	1	•	•	•	•	•
11,5 ÷ 12,4	14	1	•	•	•	•	•
12,5 ÷ 13,4	15	1	•	•	•	•	•
13,5 ÷ 14,4	16	1	•	•	•	•	•
14,5 ÷ 15	17	1,5	•	•	•	•	•
15,1 ÷ 16	18	1,5	•	•	•	•	•
16,1 ÷ 17	19	1,5	•	•	•	•	•
17,1 ÷ 18	20	1,5	•	•	•	•	•
18,1 ÷ 19	21	1,5	•	•	•	•	•
18,2 ÷ 19	21	1,5	•	•	•	•	•
19,1 ÷ 20	22	1,5	•	•	•	•	•

T5.2 ESPULSORE TESTA CILINDRICA ISO 1530-1 NITRURATO

T5.2 EJECTOR ISO 1530-1 NITRURED

T5.2 AUSWERFERSTIFT ISO 1530-1 NITRIERT

T5.202.0A

Espulsore testa cilindrica nitrurato ISO 6751-A DIN 1530-1

Nitrided ejector pin ISO 6751-A DIN1530-1

Auswerferstift nitriert ISO 6751-A DIN1530-1

Material: 1.2344

Hardness SURFACE: >1000 Vickers

Hardness HEAD: 45±5 HRC

Tolerance: g6

Tensile strenght: 1400 N/mm2

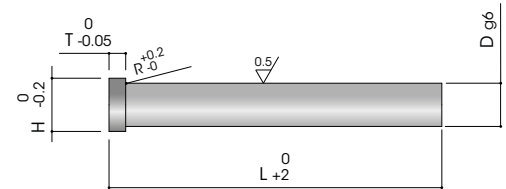

Esempio di ordine / Example of order / Bestellbeispiel:

T5.202.0A. [D][L] T5.202.0A.0800125

D	H	T	100	125	160	200	250	315	400	500	630	800	1000	1200
1	2,5	1,2	•	•	•									
1,5	3	1,5	•	•	•	•								
2	4	2	•	•	•	•	•	•	•					
2,2	4	2	•	•	•	•	•	•	•					
2,5	5	2	•	•	•	•	•	•	•	•				
2,7	5	2	•	•	•	•	•	•						
3	6	3	•	•	•	•	•	•	•	•	•			
3,2	6	3	•	•	•	•	•	•	•	•	•			
3,5	7	3	•	•	•	•	•	•	•	•	•	•		
3,7	7	3	•	•	•	•	•	•	•	•	•	•		
4	8	3	•	•	•	•	•	•	•	•	•	•	•	
4,2	8	3	•	•	•	•	•	•	•	•	•	•	•	
4,5	8	3	•	•	•	•	•	•	•	•	•	•	•	
5	10	3	•	•	•	•	•	•	•	•	•	•	•	
5,2	10	3	•	•	•	•	•	•	•	•	•	•	•	
5,5	10	3	•	•	•	•	•	•	•	•	•	•	•	
6	12	5	•	•	•	•	•	•	•	•	•	•	•	
6,2	12	5	•	•	•	•	•	•	•	•	•	•	•	
6,5	12	5	•	•	•	•	•	•	•	•	•	•	•	
7	12	5	•	•	•	•	•	•	•	•	•	•	•	
7,5	12	5	•	•	•	•	•	•	•	•	•	•	•	
8	14	5	•	•	•	•	•	•	•	•	•	•	•	•
8,2	14	5	•	•	•	•	•	•	•	•	•	•	•	
8,5	14	5	•	•	•	•	•	•	•	•	•	•	•	
9	14	5	•	•	•	•	•	•	•	•	•	•	•	
9,5	14	5	•	•	•	•	•	•	•	•	•	•	•	
10	16	5	•	•	•	•	•	•	•	•	•	•	•	•
10,2	16	5	•	•	•	•	•	•	•	•	•	•	•	
10,5	16	5	•	•	•	•	•	•	•	•	•	•	•	
11	16	5	•	•	•	•	•	•	•	•	•	•	•	
12	18	7	•	•	•	•	•	•	•	•	•	•	•	•
12,2	18	7	•	•	•	•	•	•	•	•	•	•	•	
12,5	18	7	•	•	•	•	•	•	•	•	•	•	•	
14	22	7	•	•	•	•	•	•	•	•	•	•	•	•
15,5	22	7	•	•	•	•	•	•	•	•	•	•	•	
16	22	7	•	•	•	•	•	•	•	•	•	•	•	•
18	24	7	•	•	•	•	•	•	•	•	•	•	•	
20	26	8	•	•	•	•	•	•	•	•	•	•	•	•
25	32	10	•	•	•	•	•	•	•	•	•	•	•	•
32	40	10		•	•	•	•	•	•	•	•	•	•	•

T5.2 ESPULSORE TESTA CILINDRICA ISO 1530-1 TEMPERATO

T5.2 EJECTOR ISO 1530-1 THROUGH - HARDNED

T5.2 AUSWERFERSTIFT ISO 1530-1 GEHÄRTET

T5.202.AH

Espulsore temperato ISO 6751-AH DIN 1530-1
 Hardened ejector pin ISO 6751-AH DIN 1530-1
 Auswerferstift Gehärtet ISO 6751-AH DIN 1530-1

Material: 1.2510
 Hardness SURFACE: 58-62 HRC/1100 Vickers
 Hardness HEAD: 45±5 HRC
 Tolerance: g6

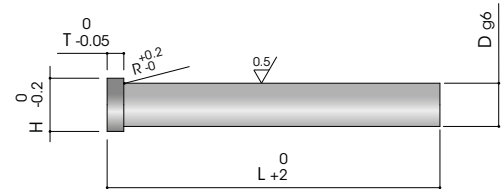

Esempio di ordine / Example of order / Bestellbeispiel:

T5.202.AH. [D][L] T5.202.AH.1200160

D	H	T	100	125	160	200	250	315	400	500
1	2,5	1,2	•	•	•					
1,1	2,5	1,2	•	•	•					
1,2	2,5	1,2	•	•	•					
1,3	3	1,5	•	•	•					
1,4	3	1,5	•	•	•					
1,5	3	1,5	•	•	•	•				
1,6	3	1,5	•	•	•					
1,7	3	1,5	•	•	•	•				
1,8	3	1,5	•	•	•					
1,9	3	1,5	•	•	•					
2	4	2	•	•	•	•	•	•		
2,2	4	2	•	•	•	•	•	•		
2,5	5	2	•	•	•	•	•	•		
2,7	5	2	•	•	•	•	•	•		
3	6	3	•	•	•	•	•	•	•	
3,2	6	3	•	•	•	•	•	•	•	
3,5	7	3	•	•	•	•	•	•	•	
3,7	7	3	•	•	•	•	•	•	•	
4	8	3	•	•	•	•	•	•	•	
4,2	8	3	•	•	•	•	•	•	•	
4,5	8	3	•	•	•	•	•	•	•	
5	10	3	•	•	•	•	•	•	•	
5,2	10	3	•	•	•	•	•	•	•	

D	H	T	100	125	160	200	250	315	400	500
5,5	10	3	•	•	•	•	•	•	•	
6	12	5	•	•	•	•	•	•	•	•
6,2	12	5	•	•	•	•	•	•	•	
6,5	12	5	•	•	•	•	•	•	•	
7	12	5	•	•	•	•	•	•	•	
7,5	12	5	•	•	•	•	•	•	•	
8	14	5	•	•	•	•	•	•	•	•
8,2	14	5	•	•	•	•	•	•	•	
8,5	14	5	•	•	•	•	•	•	•	
9	14	5	•	•	•	•	•	•	•	
9,5	14	5	•	•	•	•	•	•	•	
10	16	5	•	•	•	•	•	•	•	•
10,2	16	5	•	•	•	•	•	•	•	
10,5	16	5	•	•	•	•	•	•	•	
11	16	5	•	•	•	•	•	•	•	
12	18	7	•	•	•	•	•	•	•	•
12,2	18	7	•	•	•	•	•	•	•	
12,5	18	7	•	•	•	•	•	•	•	
14	22	7	•	•	•	•	•	•	•	
16	22	7	•	•	•	•	•	•	•	•
18	24	7	•	•	•	•	•	•	•	
20	26	8	•	•	•	•	•	•	•	•

T5.2 ESPULSORE TESTA CILINDRICA ISO 1530-1 FIAT

T5.2 EJECTOR 1530-1 FIAT

T5.2 AUSWERFERSTIFT 1530-1 FIAT

T5.206.0A

Espulsore testa cilindrica niturato FIAT DIN 1530-1

Nitrided ejector PIN FIAT DIN1530-1

Auswerferstift nitriert FIAT DIN1530-1

Material: 1.2344

Hardness SURFACE: >1000 Vickers

Hardness HEAD: 45±5 HRC

Tolerance: g6

Tensile strength: 1400 N/mm²

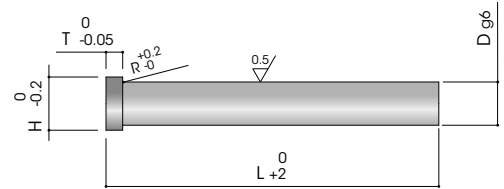

Esempio di ordine / Example of order / Bestellbeispiel:

T5.202.0A [D][L] T5.202.0A.0800125

D	H	T	100	125	160	200	250	315	400	500	630	800	1000
3,5	6	3	•	•	•	•	•	•	•				
4	8	4	•	•	•	•	•	•	•				
4,2	8	4	•	•	•	•	•	•	•				
4,5	8	4	•	•	•	•	•	•	•				
5	10	5	•	•	•	•	•	•	•	•			
5,2	10	5	•	•	•	•	•	•	•				
5,5	10	5	•	•	•	•	•	•	•	•			
8	14	6,5	•	•	•	•	•	•	•	•			
8,2	14	6,5	•	•	•	•	•	•	•	•	•		
8,5	14	6,5	•	•	•	•	•	•	•				
9	14	6,5	•	•	•	•	•	•	•	•			
10	16	6,5	•	•	•	•	•	•	•	•			
10,2	16	6,5	•	•	•	•	•	•	•	•	•	•	•
10,5	16	6,5	•	•	•	•	•	•	•	•			
11	18	6,5	•	•	•	•	•	•	•	•			
12	18	6,5	•	•	•	•	•	•	•	•			
16	24	7	•	•	•	•	•	•	•	•			
18	26	7	•	•	•	•	•	•	•	•			
20	28	7	•	•	•	•	•	•	•	•			

NOTES



SYNDAL srl

Via Cesare Battisti 2
20090 Trezzano sul Naviglio (MI)
T +39 02 4842051

Via I Maggio 10
40011 Anzola dell'Emilia (BO)
T +39 051 0561910

info@syndal.it
syndal.it